

VDI DESTRO
VDI Right hand
VDI Recht

PER ALBERI E DISTANZIALI VEDI PAG. TBL250-1-00
FOR SHAFT END SPACER SEE PAGE TBL250-1-00
FUER DORN UND ABSTANDSSTUECK SEITE TBL250-1-00

DOTAZIONI - SUPPLIED WITH - AUSSTATTUNG

mm / inch	- N°1 ALBERO + DISTANZIALI
	- N°1 SHAFT + SPACER
	- N°1 DORN + ABSTANDSSTUECK

-LA FUNZIONE DI POLIGONATURA/DENTATURA
DEVE ESSERE INSTALLATA SULLA MACCHINA
-POLYGON CUTTING/GEAR HOBBIING FUNCTION
MUST BE INSTALLED ON THE MACHINE
-DIE FUNKTION FÜR POLYGON-BZW .VERZÄHNUNGSFRÄSEN
MUSS AUF DER MASCHINE FREIGESCHALTET WERDEN

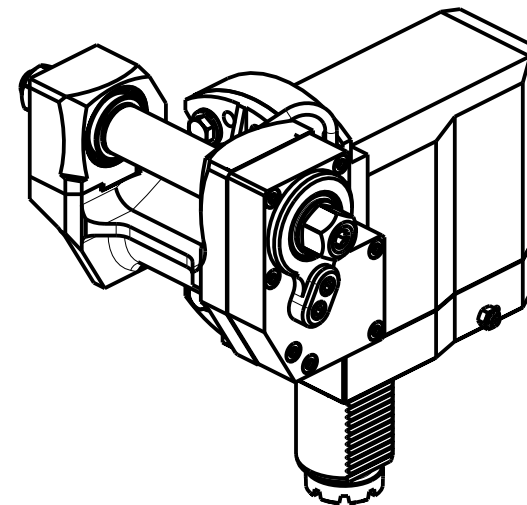
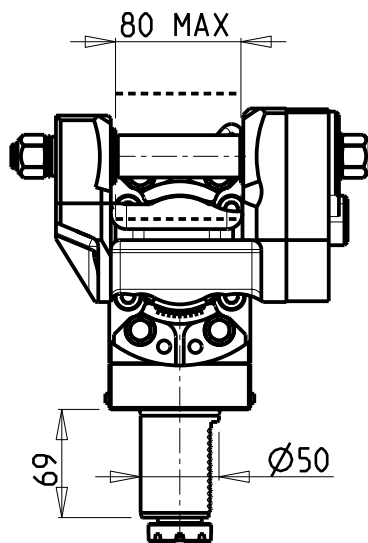
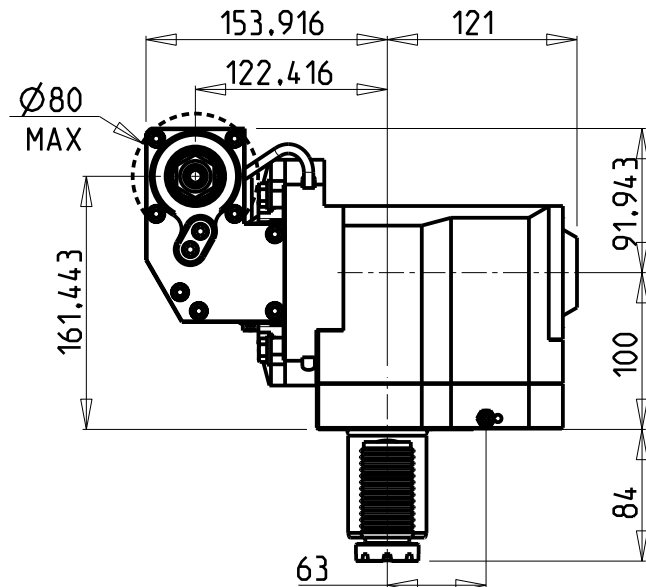

**TORRETTE ASSIALI
AXIAL TURRETS
AXIAL REVOLVER**

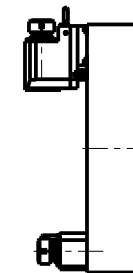

Cod. MT	I	RPM max	Coppia Max Max Torque Max Drehmoment	Lubrificazione est. Ext. coolant Aussenkuehlung	D (mm)	D (Inch)	CHIAVI INCLUSE Keys included Schlüssel inbegriffen	VDI
BAR0051100	1:1	4000	60Nm	X	16-22-27-32	3/4"-1"-1 1/4"	CHUB24 CHUB13 CHESL08	DESTRO - Right - Recht
BAR0052100	2:1	2000	80Nm	X	16-22-27-32	3/4"-1"-1 1/4"	CHUB24 CHUB13 CHESL08	DESTRO - Right - Recht

BARUFFALDI
VDI 50

MODULO MOTORIZZATO PORTACREATORE VDI50
Driven gear hobber VDI50
Angetriebenes Zahnradwaelzfraes-Werkzeug VDI50

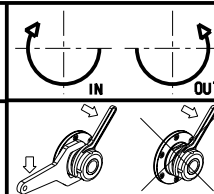

M.T. srl
Via Casino Albini 480
Tel. 0541/956034-957884
Fax 0541/956341
47842 S. GIOVANNI IN M. (RN)
e-mail: mtma@tmarchetti.com
http://www.tmmarchetti.com



BAR340-3-00

Subject to change without notice.

03/2024