

### ATTENZIONE - ATTENTION - ACHTUNG

- Per lo smontaggio degli utensili utilizzare sempre la chiave di contrasto come indicato nel manuale d'uso.
- For disassembly of the tools use always the contrast key as mentioned in the user instructions.
- Fuer das Abmontieren der Werkzeuge immer den Gegenschlüssel benutzen wie in der Bedienungsanleitung erwaeht.

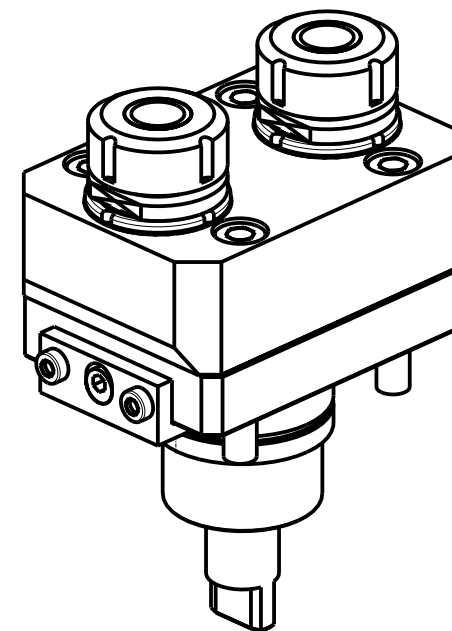

Cod. MT	Mandrino Spindle Spindel	I	RPM	Coppia Max Max Torque Max Drehmoment	Lubrificazione est. Ext. coolant Aussenkuehlung	A	CHIAVI NON INCLUSE Keys not included Schlüssel nicht einbegriffen	
BGL0020225	ER25	1:2	12000	20Nm	X	88.96	CHSTER25	CHUB36

**BIGLIA**  
 MOD: B301/445/470/501(Y-S)/510/545/550/565/620/650/658/1200/446/465/745/765 - B750/1250 16 ST.

MODULO MOTORIZZATO RADIALE 2 USCITE IN Z MOLTIPLICATO I=1:2  
 Radial geared-up I=1:2 twin head driven tool in Z  
 Radial angetriebenes Werkzeug 2 Ausgaenge in Z uebersetzt I=1:2

Subject to change without notice.

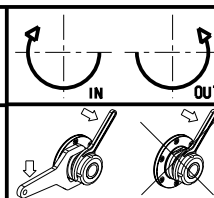

**M.T. srl**  
 Via Casino Albini 480  
 Tel. 0541/956034-957884  
 Fax 0541/956341  
 47842 S. GIOVANNI IN M. (RN)  
 e-mail: mtma@mtmarchetti.com  
 http://www.mtmarchetti.com



PAGINA BGL090-1-00