

## CUSCINETTI MAGGIORATI PER LAVORAZIONI PESANTI

Reinforced bearings for  
heavy machining

Vergroesserte Lager fuer  
schwerere Bearbeitungen

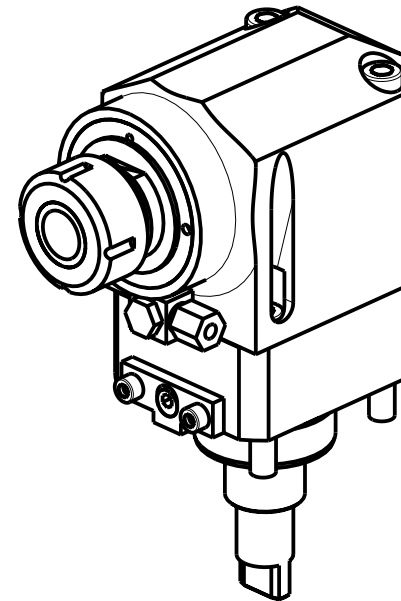
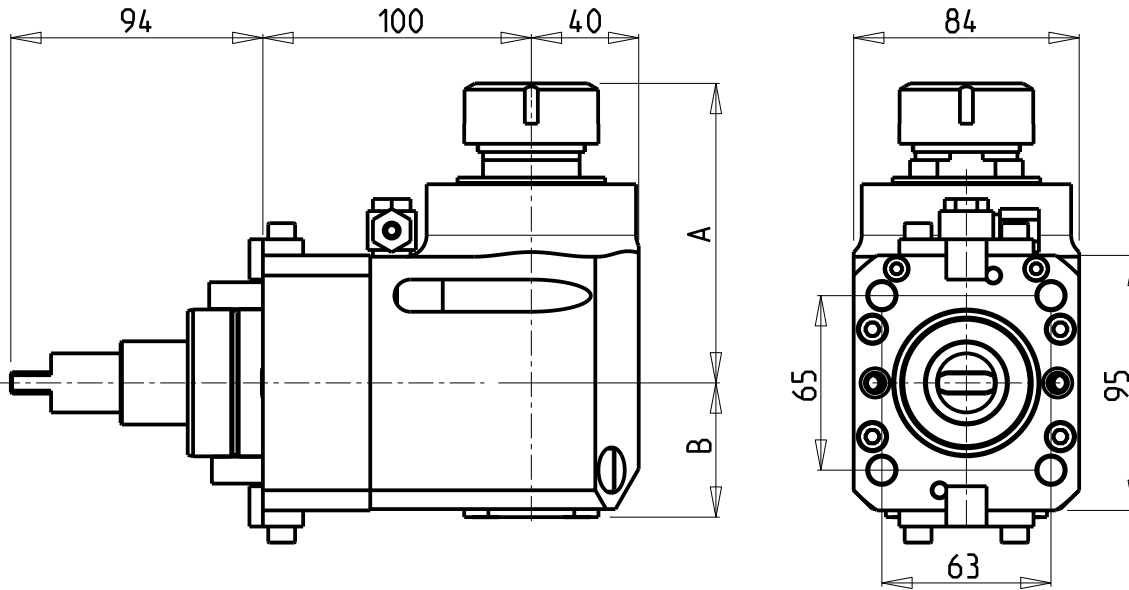

Cod. MT	Mandrino Spindle Spindel	I	RPM	Coppia Max Max Torque Max Drehmoment	Reversibile lato mandrino/contromandrino Reversible sub/main spindle side Umkehrbare Spindel-seite/ Gegenspindel-seite	Lubrificazione int. Coolant through Innenkuehlung	Lubrificazione est. Ext. coolant Aussenkuehlung	A	B	CHIAVI NON INCLUSE Keys not included Schluessel nicht einbegriffen	
										CHSTER32	CHUB36
0391432L	ER32	1:1	6000	70Nm	X	-	X	112.16	50	CHSTER32	CHUB36
0391032L	ER32	1:1	6000	70Nm	X	P=70bar	X	112.16	61	CHSTER32	CHUB36
0391532L	ERA32	1:1	6000	70Nm	X	-	X	99.03	50	CHUB50	CHUB32
0392640L	ER40	1:1	6000	70Nm	X	-	X	115.16	50	CHSTER40	CHUB46
0392540L	ER40	1:1	6000	70Nm	X	P=70bar	X	115.16	61	CHSTER40	CHUB46

**BIGLIA**  
MOD: B445/470/545/550/565/650/658/1200/446/465/745/765 - B750/1250 16 ST.

MODULO MOTORIZZATO ASSIALE MAGGIORATO H=100mm  
Axial reinforced driven tool H=100mm  
Axial angetriebenes Werkzeug vergroessert H=100mm

Subject to change without notice.

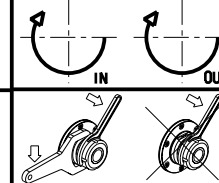

**M.T. srl**

Via Casino Albini 480  
Tel. 0541/956034-957884  
Fax 0541/956341  
47842 S. GIOVANNI IN M. (RN)  
e-mail: mtma@mtmarchetti.com  
http://www.mtmarchetti.com



PAGINA BGL170-1-20