

### ATTENZIONE - ATTENTION - ACHTUNG

- Con l'utensile orientato a 0° o 180°, non è possibile eseguire lavorazioni a centro-pezzo!
- It is not possible to make machining operations at the center of the part with tool oriented at 0° or at 180°.
- Mit einem Werkzeug um 0° oder 180° orientiert, ist es nicht möglich, Verarbeitung von der Werkzeug-Mitte auszuführen.

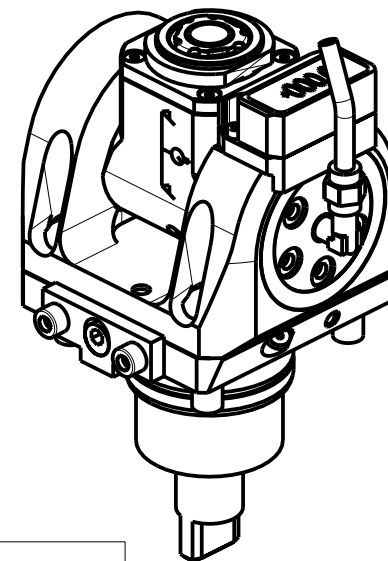

Cod. MT	Mandrino Spindle Spindel	I	RPM	Coppia Max Max Torque Max Drehmoment	Reversibile lato mandrino/contromandrino Reversible sub/main spindle side Umkehrbare Spindel-seite/ Gegenspindel-seite	Lubrificazione int. Coolant through Innenkuehlung	Lubrificazione est. Ext. coolant Aussenkuehlung	CHIAVI INCLUSE Keys included Schlüssel inbegriffen			
								CHUB22	CHUB36	CHESL07	CHTAER20ZC
BGL0155120	ERA20	1:1	6000	30Nm	X	-	X	CHUB22	CHUB36	CHESL07	CHTAER20ZC
BGL0155220	ERA20	1:1	6000	30Nm	X	P=70bar	X	CHUB22	CHUB36	CHESL07	CHTAER20ZC

**BIGLIA**  
 MOD: B301/445/470/501(Y-S)/510/545/550/565/620/650/658/1200/446/465/745/765 - BV210/315

MODULO MOTORIZZATO ORIENTABILE ±90° CON NONIO DIGITALE  
 ±90° adjustable angle driven tool with digital display  
 Angetriebenes Werkzeug schwenkbar ±90° mit digital display

Subject to change without notice.

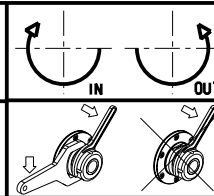

**M.T. srl**  
 Via Casino Albini 480  
 Tel. 0541/956034-957884  
 Fax 0541/956341  
 47842 S. GIOVANNI IN M. (RN)  
 e-mail: mtma@mtmarchetti.com  
 http://www.mtmarchetti.com



PAGINA BGL335-1-01