

**ATTENZIONE - ATTENTION - ACHTUNG**

- VERIFICARE LE MISURE DI INGOMBRO PER POSSIBILE INTERFERENZA SU ALCUNI MODELLI DI MACCHINE
- Please check the overall sizes for possible interferences on some machine models
- Bitte überprüfen sie das ausmass um mögliche interferenzen auf einigen maschinen modellen zu vermeiden

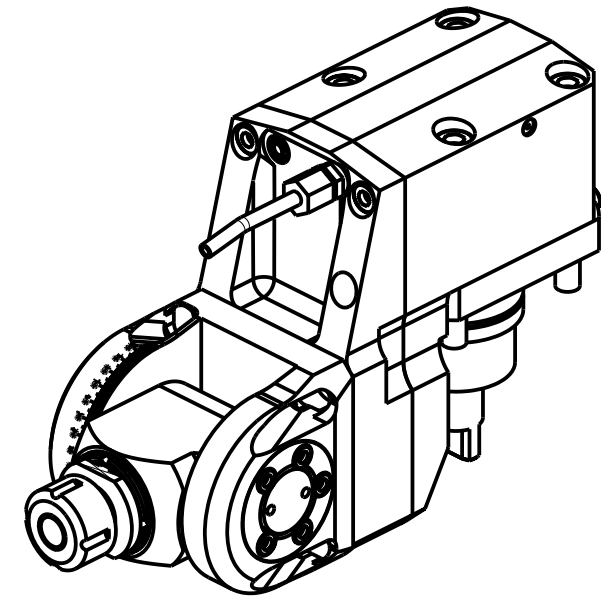

Cod. MT	Mandrino Spindle Spindel	I	RPM	Coppia Max Max Torque Max Drehmoment	Lubrificazione est. Ext. coolant Aussenkuehlung	A	CHIAVI INCLUSE Keys included Schluessel inbegriffen	
							CHSTER20	CHUB36
BGL0580120	ER20	1:1	6000	40Nm	X	85.16	CHSTER20	CHUB36
BGL0580125	ER25	1:1	6000	40Nm	X	86.16	CHSTER25	CHUB36

**BIGLIA**  
 MOD: B301/445/470/501(Y-S)/510/545/550/565/620/650/658/1200/446/465/745/765

MODULO MOTORIZZATO ORIENTABILE  $\pm 90^\circ$  ARRETRATO  
 $\pm 90^\circ$  adjustable angle rear-set driven tool  
 Angetriebenes Werkzeug schwenkbar  $\pm 90^\circ$  zurueckversetzt

Subject to change without notice.

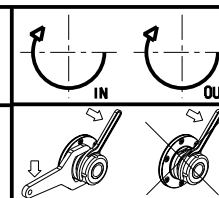

**M.T. srl**  
 Via Casino Albini 480  
 Tel. 0541/956034-957884  
 Fax 0541/956341  
 47842 S. GIOVANNI IN M. (RN)  
 e-mail: mtma@mtmarchetti.com  
 http://www.mtmarchetti.com



PAGINA BGL356-1-00