

ATTENZIONE - ATTENTION - ACHTUNG

- VERIFICARE LE MISURE DI INGOMBRO PER POSSIBILE INTERFERENZA SU ALCUNI MODELLI DI MACCHINE
- Please check the overall sizes for possible interferences on some machine models
- Bitte überprüfen sie das ausmass um mögliche interferenzen auf einigen maschinen modellen zu vermeiden

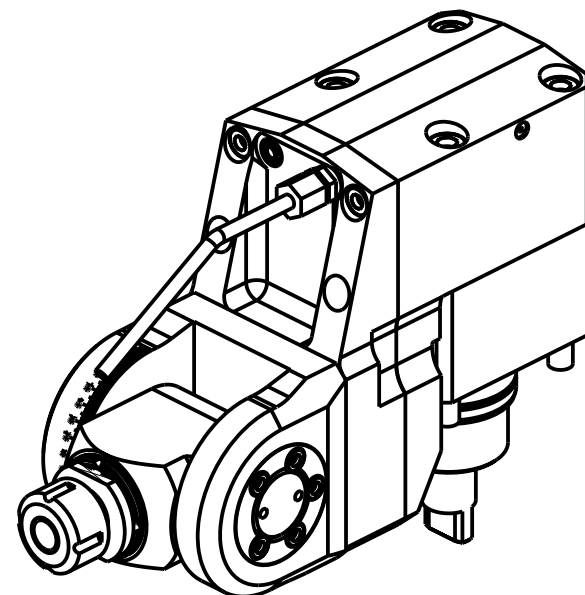

Cod. MT	Mandrino Spindle Spindel	I	RPM	Coppia Max Max Torque Max Drehmoment	Lubrificazione est. Ext. coolant Aussenkuehlung	A	CHIAVI INCLUSE Keys included Schluessel inbegriffen	
BGL0720120	ER20	1:1	6000	40Nm	X	85.16	CHSTER20	CHUB36
BGL0720125	ER25	1:1	6000	40Nm	X	86.16	CHSTER25	CHUB36

BIGLIA

MOD: B750/1250 16 ST.

MODULO MOTORIZZATO ORIENTABILE $\pm 90^\circ$ ARRETRATO

$\pm 90^\circ$ adjustable angle rear-set driven tool

Angetriebenes Werkzeug schwenkbar $\pm 90^\circ$ zurueckversetzt

Subject to change without notice.

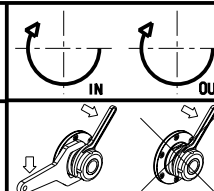

M.T. srl

Via Casino Albini 480
Tel. 0541/956034-957884
Fax 0541/956341

47842 S. GIOVANNI IN M. (RN)
e-mail: mtma@mtmarchetti.com
http://www.mtmarchetti.com



PAGINA BGL356-1-10