

ATTENZIONE - ATTENTION - ACHTUNG

-Su macchine B545/B565/B650 non utilizzare su lato contromandrino.

-On B545/B565/B650 do not use on sub-spindle side.

-Auf B545/B565/B650 Maschinen nicht auf der gegenspindel-seite benutzen.

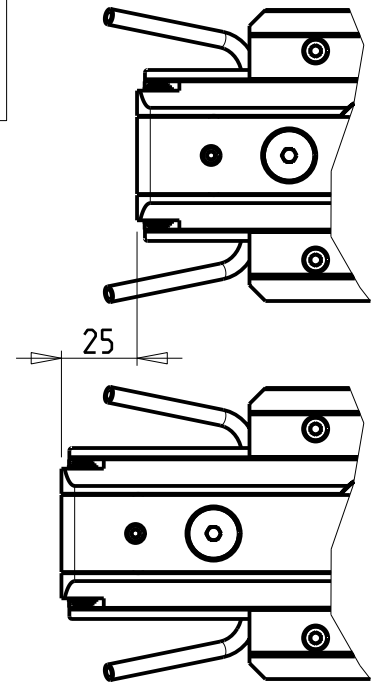
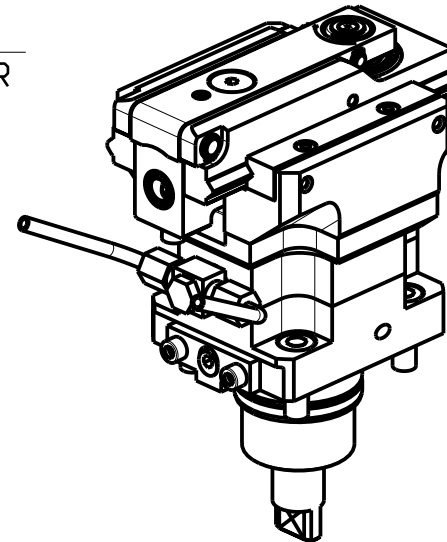

DOTAZIONI - SUPPLIED WITH - AUSSTATTUNG

N°1 Boccola di riduz. Ø16-Ø12 e N°1 Boccola di riduz. Ø16-Ø10
 N°1 Reduction bush Ø16-Ø12 and N°1 Reduction bush Ø16-Ø10
 N°1 Reduzierbuchsen Ø16-Ø12 und N°1 Reduzierbuchsen Ø16-Ø10

PER UTENSILI STOZZATORI VEDI PAG. TBL400-1-00
 FOR DRIVEN SLOTTING TOOL CUTTING-TOOLS SEE PAGE TBL400-1-00
 FÜR NUTENSTOSS-WERKZEUG SCHNEIDWERKZEUGE SIEHE SEITE TBL400-1-00

Cod. MT	I	RPM MAX	Reversibile lato mandrino/contromandrino Reversible sub/main spindle side Umkehrbare Spindel-seite/ Gegenspindel-seite	Lubr. esterna Ext. coolant Aussenkuehlung
BGL0330200	4:1	2400	X	X

BIGLIA
 MOD: B445/470/545/550/565/650/658/1200/446/465/745/765 - B750/1250 16 ST.

MODULO MOTORIZZATO STOZZATORE CORSA 25mm H=100mm
 Slotting driven tool 25mm stroke H=100mm
 Keilnutenstossmaschine 25mm Hub H=100mm

M.T. srl
 Via Casino Albini 480
 Tel. 0541/956034-957884
 Fax 0541/956341
 47842 S. GIOVANNI IN M. (RN)
 e-mail: mtma@mtmarchetti.com
 http://www.mtmarchetti.com



PAGINA BGL360-1-11

Subject to change without notice.

09/2023