

ATTENZIONE - ATTENTION - ACHTUNG

- VERIFICARE LE MISURE DI INGOMBRO PER POSSIBILE INTERFERENZA SU ALCUNI MODELLI DI MACCHINE
- Please check the overall sizes for possible interferences on some machine models
- Bitte überprüfen sie das ausmass um mögliche interferenzen auf einigen maschinen modellen zu vermeiden

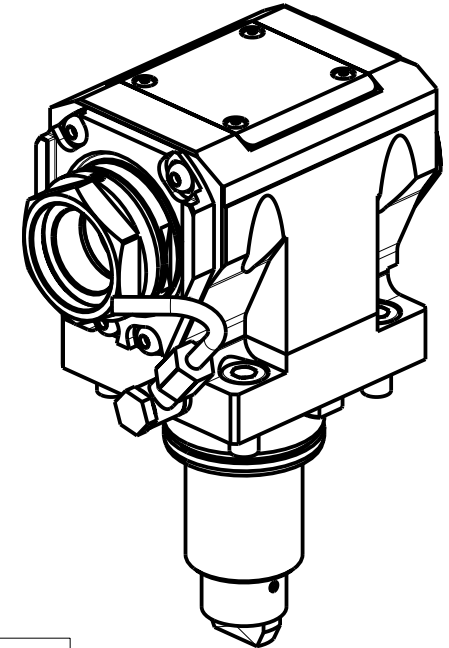
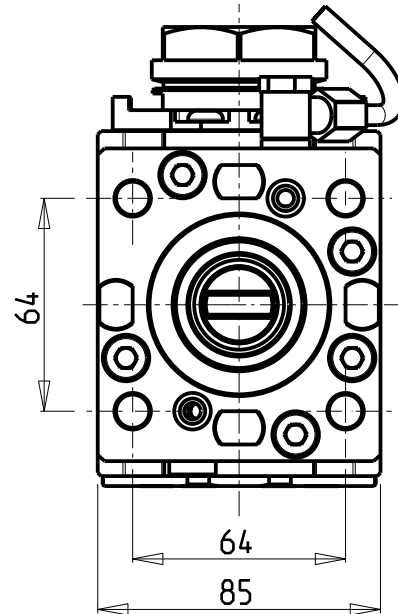
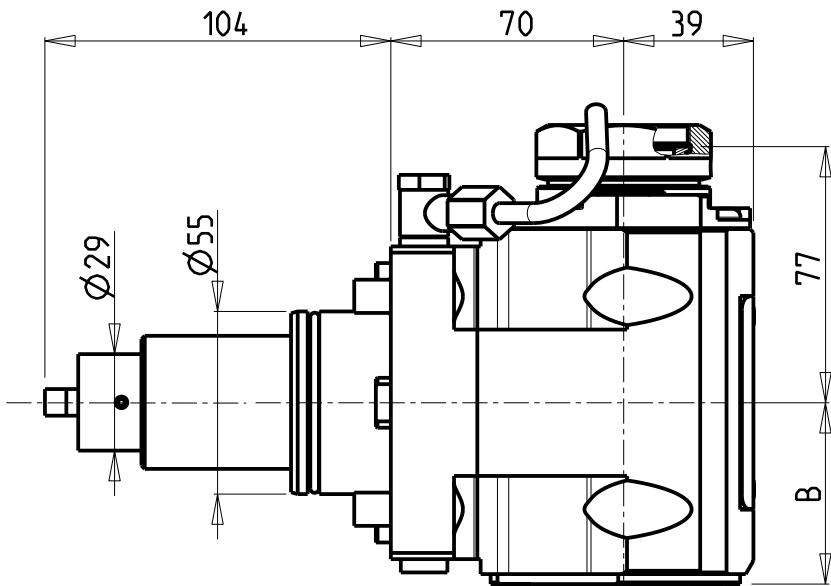

- Chiave inclusa
- Key included
- Schlüssel inbegriffen

PER PORTAUTENSILI MODULARI MTSK-40 VEDI PAG. TBL300-1-40
 FOR MTSK-40 QUIK CHANGE TOOLHOLDERS CLAMPINGS SEE PAGE TBL300-1-40
 FUER MTSK-40 MODULARE WERKZEUGAUFNAHMEN SIEHE SEITE TBL300-1-40

Cod. MT	Mandrino Spindle Spindel	I	RPM	Coppia Max Max Torque Max Drehmoment	Reversibile lato mandrino/contromandrino Reversible sub/main spindle side Umkehrbare Spindel-seite/ Gegenspindel-seite	Lubr.interna Coolant through Innenkuehlung	Lubr.esterna Ext. coolant Aussenkuehlung	B	CHIAVI NON INCLUSE Keys not included Schlüssel nicht einbegriffen	
DW 00780140	MTSK-40	1:1	6000	70Nm	X	-	X	54.5	CHUB46	OKU0650004
DW 00780240	MTSK-40	1:1	6000	70Nm	X	P=70bar	X	65.5	CHUB46	OKU0650004

CHIAH CHYUN
 MOD: WTS-52/65 Y2M 16ST. - ML-250
 MODULO MOTORIZZATO ASSIALE MTSK H=70mm
 Axial MTSK driven tool H=70mm
 Axial MTSK angetriebenes Werkzeug H=70mm

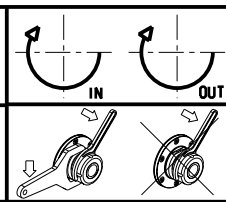

M.T. srl
 Via Casino Albini 480
 Tel. 0541/956034-957884
 Fax 0541/956341
 47842 S. GIOVANNI IN M. (RN)
 e-mail: mtma@mtmarchetti.com
 http://www.mtmarchetti.com

CCM150-2-21-K

Subject to change without notice.