

**ATTENZIONE - ATTENTION - ACHTUNG**

- VERIFICARE LE MISURE DI INGOMBRO PER POSSIBILE INTERFERENZA SU ALCUNI MODELLI DI MACCHINE
- Please check the overall sizes for possible interferences on some machine models
- Bitte überprüfen sie das ausmass um mögliche interferenzen auf einigen maschinen modellen zu vermeiden

**ATTENZIONE - ATTENTION - ACHTUNG**

- PRIMA DI UTILIZZARE IL MOTORIZZATO CONSULTARE LE ISTRUZIONI ALLEGATE!
- BEFORE USING THE DRIVEN TOOL, PLEASE CHECK THE ENCLOSED INSTRUCTION SHEET!
- VOR DER BENUTZUNG DES ANGETRIEBENEN WERKZEUGES, DIE BEILIEGENDEN INSTRUKTIONEN DURCHLESEN!

**ATTENZIONE - ATTENTION - ACHTUNG**

- Per lo smontaggio degli utensili utilizzare sempre la chiave di contrasto come indicato nel manuale d'uso.
- For disassembly of the tools use always the contrast key as mentioned in the user instructions.
- Fuer das Abmontieren der Werkzeuge immer den Gegenschluesel benutzen wie in der Bedienungsanleitung erwaeht.

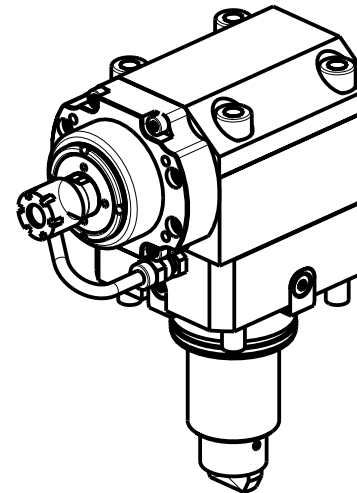
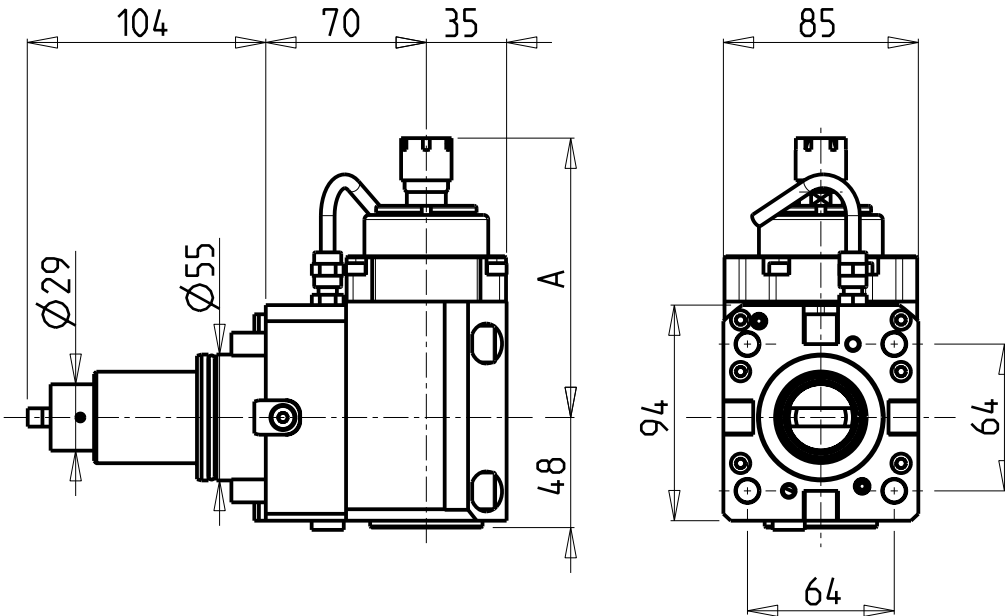

Cod. MT	Mandrino Spindle Spindel	I	RPM MAX	Coppia Max Max Torque Max Drehmoment	Reversibile lato mandrino/contromandrino Reversible sub/main spindle side Umkehrbare Spindel-seite/ Gegenspindel-seite	Lubrificazione int. Coolant through Innenkuehlung	Lubrificazione est. Ext. coolant Aussenkuehlung	A	CHIAVI INCLUSE Keys included Schluesel einbegriffen	
DW 00190316	ER16	1:5.625	22500	6Nm	X		X	121.8	CHMNER16	CHUB17
DW 00190311	ER11	1:5.625	22500	6Nm	X	P=30bar		134	CHMNER11	CHUB11

CHIAH CHYUN

MOD: WTS-52/65 Y2M 16ST. - ML-250

MODULO MOTORIZZATO ASSIALE MOLTIPLICATO I=1:5.625 H=70mm

Axial geared-up I=1:5.625 driven tool H=70mm

Axial angetriebenes Werkzeug uebersetzt I=1:5.625 H=70mm

Subject to change without notice.

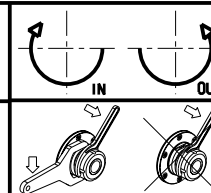

**M.T. srl**

Via Casino Albini 480  
Tel. 0541/956034-957884  
Fax 0541/956341  
47842 S. GIOVANNI, IN M. (RN)  
e-mail: mtma@mtmarchetti.com  
http://www.mtmarchetti.com



CCM210-2-20