

ATTENZIONE - ATTENTION - ACHTUNG

- VERIFICARE LE MISURE DI INGOMBRO PER POSSIBILE INTERFERENZA SU ALCUNI MODELLI DI MACCHINE
- Please check the overall sizes for possible interferences on some machine models
- Bitte überprüfen sie das ausmass um mögliche interenzen auf einigen maschinen modellen zu vermeiden

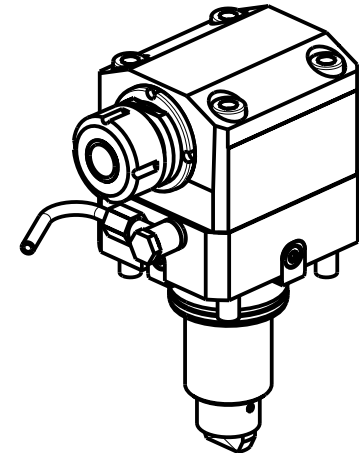
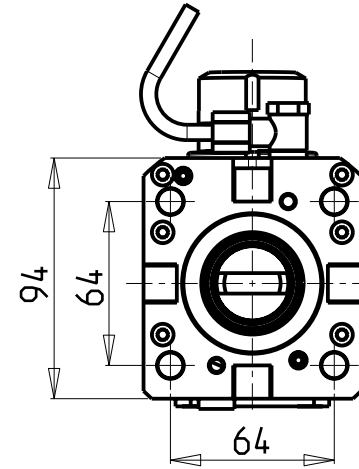
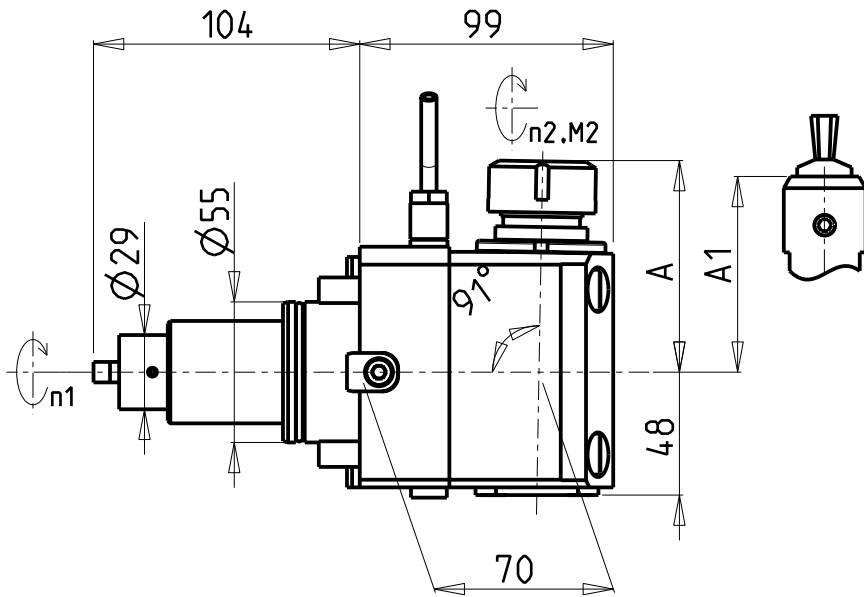

Cod. MT	Mandrino Spindle	I (n1:n2)	RPM max n2	Coppia Max Max Torque Max Drehmoment M2 (Nm)	Reversibile 180° 180° Reversible 180° umsetzbar	Lubrificazione est. Ext. coolant Aussekkuehlung	Lav. secco Dry-run Trocken Bearb.	A	A1	CHIAVI NON INCLUSE Keys not included Schlüssel nicht einbegriffen	
DW00249125	ER25	1:1	6000	50	X	X	X	82.35	-	CHSTER25	CHUB36 o 0100000
DW00249108	WELDON 8	1:1	6000	50	X	X	X	-	76.5	-	-
DW00249110	WELDON 10	1:1	6000	50	X	X	X	-	76.5	-	-
DW00249112	WELDON 12	1:1	6000	50	X	X	X	-	76.5	-	-
DW00249116	WELDON 16	1:1	6000	50	X	X	X	-	76.5	-	-

CHIAH CHYUN
 MOD: WTS-52/65 Y2M 16ST. - ML-250
 MODULO MOTORIZZATO ASSIALE PER POLIGONATURA INTERNA H=70mm
 Axial driven tool for internal polygon-making H=70mm
 Axial angetriebenes Werkzeug fuer interne Facettierung H=70mm

M.T. srl
 Via Casino Albini 480
 Tel. 0541/956034-957884
 Fax 0541/956341
 47842 S. GIOVANNI IN M. (RN)
 e-mail: mtma@mtmarchetti.com
 http://www.mtmarchetti.com



CCM230-2-20

Subject to change without notice.