

**ATTENZIONE - ATTENTION - ACHTUNG**

- Per lo smontaggio degli utensili utilizzare sempre la chiave di contrasto come indicato nel manuale d'uso.
- For disassembly of the tools use always the contrast key as mentioned in the user instructions.
- Fuer das Abmontieren der Werkzeuge immer den Gegenschlüssel benutzen wie in der Bedienungsanleitung erwäehnt.

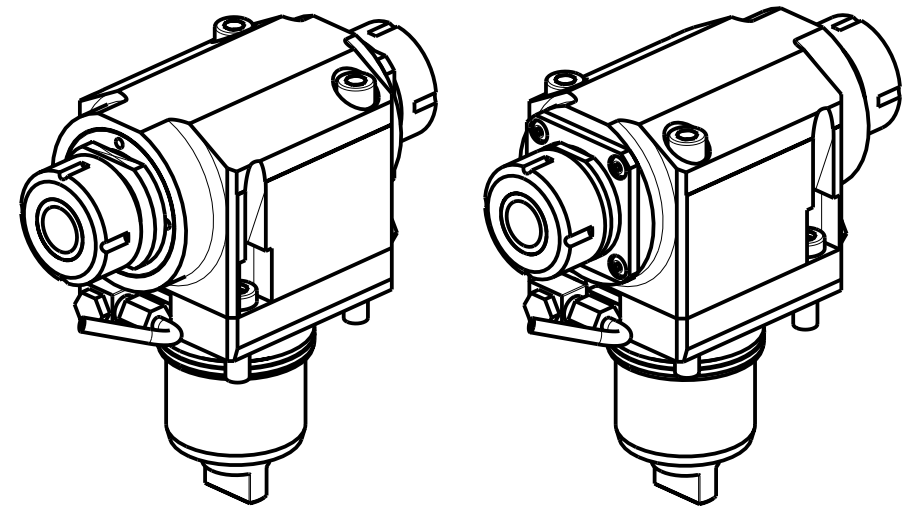

Cod. MT	Mandrino Spindle Spindel	I	RPM	Coppia Max Max Torque Max Drehmoment	Reversibile lato mandrino/contromandrino Reversible sub/main spindle side Umkehrbare Spindel-seite/ Gegenspindel-seite	Lubrificazione est. Ext. coolant Aussenkuehlung	A	B	CHIAVI NON INCLUSE Keys not included Schluessel nicht einbegriffen	
									CHSTER32	CHUB46
NKM0600232	ER32+ER32	1:1	6000	70Nm	X	X	102.66	94.26	CHSTER32	CHUB46
NKM0600240	ER40+ER40	1:1	6000	70Nm	X	X	106.16	107.16	CHSTER40	CHUB46

**CHIAH CHYUN**  
 MOD: CT1/CT2/CT3-52/65/76 YM/Y2M/Y2MS  
 MODULO MOTORIZZATO ASSIALE BISPORGENTE H=65mm  
 Axial opposite face twin driven tool H=65mm  
 Axial angetriebenes Werkzeug halb vorspringend H=65mm

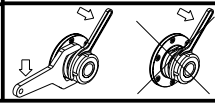

**M.T. srl**  
 Via Casino Albini 480  
 Tel. 0541/956034-957884  
 Fax 0541/956341  
 47842 S. GIOVANNI IN M. (RN)  
 e-mail: mtma@mtmarchetti.com  
 http://www.mtmarchetti.com



CCM240-1-10

Subject to change without notice.