

versione dx  
right version  
version rechts

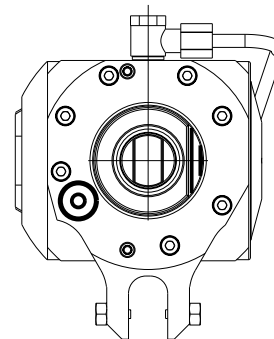

versione sx  
left version  
version links

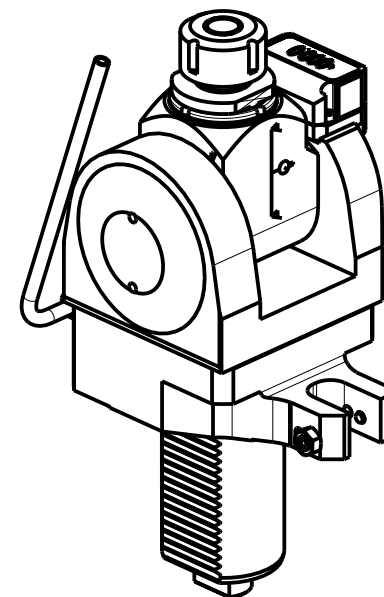
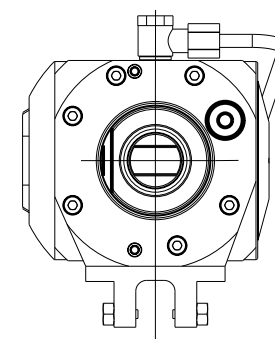

Cod. MT		Mandrino Spindle Spindel	I	RPM	Coppia Max Max Torque Max Drehmoment	Lubrificazione est. Ext. coolant Aussenkuehlung	A	A1	D	L	CHIAVI INCLUSE Keys included Schluessel einbegriffen	
versione dx right version version rechts	versione sx left version version links										CHUB36	CHSTER
DUP0460120	DUP0461120	ER20	1:1	4000	40Nm	X	85.16	-	-	-	CHUB36	CHSTER20
DUP0460125	DUP0461125	ER25	1:1	4000	40Nm	X	86.16	-	-	-	CHUB36	CHSTER25
DUP0460516	DUP0461516	Ø16x17	1:1	4000	40Nm	X	-	65	16	17	CHUB36	CH_VTCROCE_M08
DUP0460522	DUP0461522	Ø22x19	1:1	4000	40Nm	X	-	66	22	19	CHUB36	CH_VTCROCE_M10
DUP0460519	DUP0461519	Ø3/4"x3/4"	1:1	4000	40Nm	X	-	65	3/4"	3/4"	CHUB36	CH_VTCROCE_M08

DIPLOMATIC  
VDI 50

MODULO MOTORIZZATO ORIENTABILE ±90° CON NONIO DIGITALE VDI50  
±90° adjustable angle driven tool with digital display VDI50  
Angetriebenes Werkzeug schwenkbar ±90° mit digital display VDI50

Subject to change without notice.

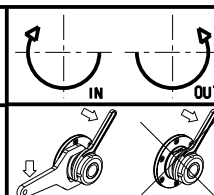

**M.T. srl**

Via Casino Albini 480  
Tel. 0541/956034-957884  
Fax 0541/956341  
47842 S. GIOVANNI IN M. (RN)  
e-mail: mtma@mtmarchetti.com  
http://www.mtmarchetti.com



DUP333-3-01

03/2024