

## CUSCINETTI MAGGIORATI PER LAVORAZIONI PESANTI

Reinforced bearings for  
heavy machining

Vergroesserte Lager fuer  
schwerere Bearbeitungen

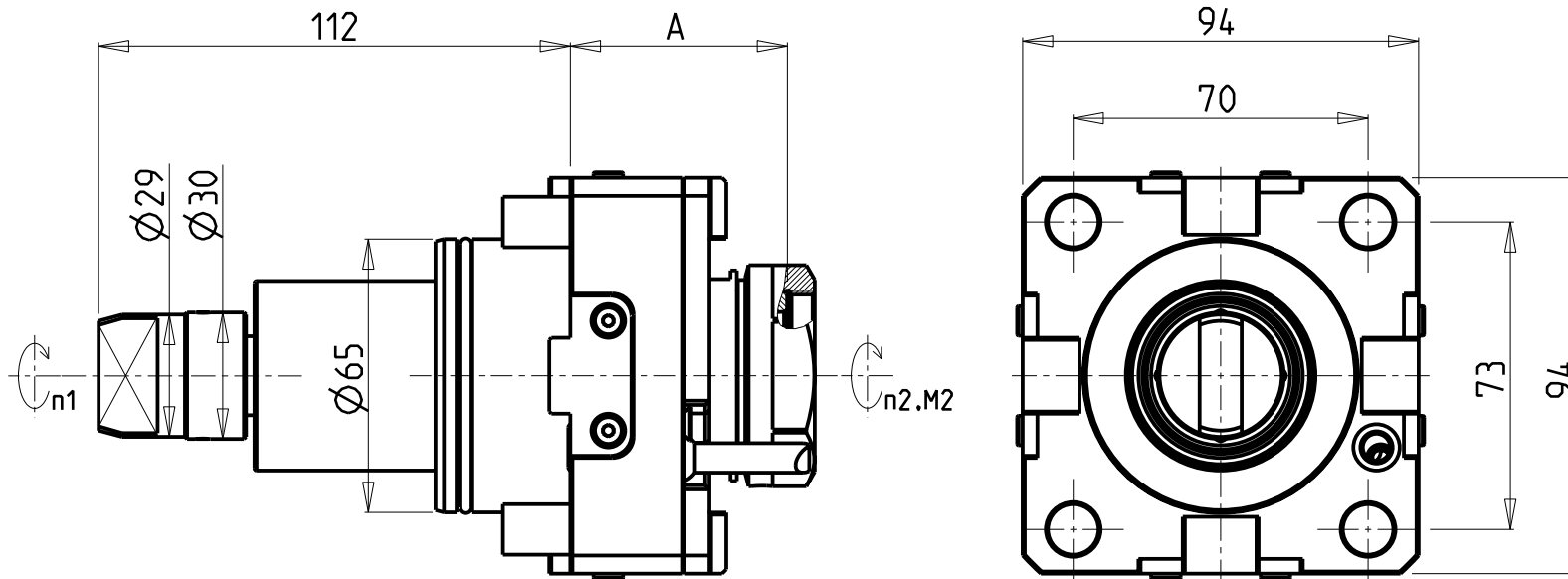
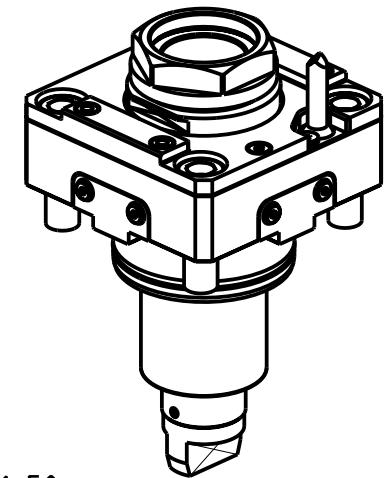

PER PORTAUTENSILI MODULARI MTSK-40 VEDI PAG. TBL300-1-40 E PER MTSK-50 VEDI PAG. TBL300-1-50  
FOR MTSK-40 QUICK CHANGE TOOLHOLDERS CLAMPINGS SEE PAGE TBL300-1-40 AND FOR MTSK-50 SEE PAGE TBL300-1-50  
FUER MTSK-40 MODULARE WERKZEUGAUFNAHMEN SIEHE SEITE TBL300-1-40 UND FUER MTSK-50 SIEHE SEITE TBL300-1-50

Cod. MT	Mandrino Spindle Spindel	I (n1:n2)	RPM max n2	Coppia Max Max Torque Max Drehmoment	Lubrificazione int. Coolant through Innenkuehlung	Lubrificazione est. Ext. coolant Aussenkuehlung	A	CHIAVI NON INCLUSE Keys not included Schluessel nicht einbegriffen	
				M2 (Nm)	Pmax (bar)	X			
DW 01550140	MTSK-40	1:1	6000	100	-	X	51.5	CHUB46	OKU0650004
DW 03480240	MTSK-40	1:1	6000	100	70	X	62.5	CHUB46	OKU0650004
DW 01550150	MTSK-50	1:1	6000	100	-	X	51.5	CHUB55	OKU0650004
DW 03480250	MTSK-50	1:1	6000	100	70	X	62.5	CHUB55	OKU0650004

- Chiave inclusa
- Key included
- Schluessel inbegriffen

### DN SOLUTIONS (DOOSAN) BMT 65

MOD: PUMA 300M/MS - V400M - TT2000SY-TT2500SY-TT2500MS - PUMA 2100-2600M/MS/Y/SY (BMT65) - PUMA 3100 M/Y - MX2000ST  
MX2500LT/ST/LST - MX2600T-ST - VT 450M/TM - PUMA INVERTURN 3000M - PUMA GT3100 M - SMX2600/3100ST - PUMA DNT2100-2600M (BMT65)

MODULO MOTORIZZATO RADIALE MAGGIORATO MTSK  
Radial MTSK reinforced driven tool  
Radial MTSK angetriebenes Werkzeug vergroessert

Subject to change without notice.

### M.T. srl

Via Casino Albini 480  
Tel. 0541/956034-957884  
Fax 0541/956341  
47842 S. GIOVANNI IN M. (RN)  
e-mail: mtma@tmarchetti.com  
http://www.tmmarchetti.com



DW 0020-3-01-K