

CUSCINETTI MAGGIORATI PER LAVORAZIONI PESANTI

Reinforced bearings for
heavy machining

Vergroesserte Lager fuer
schwerere Bearbeitungen

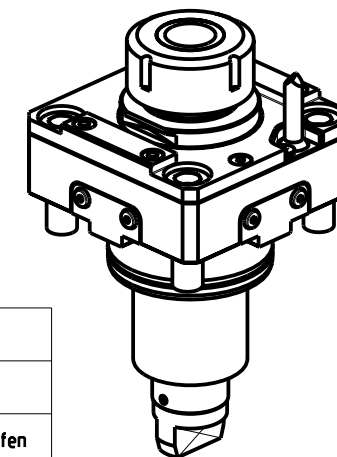
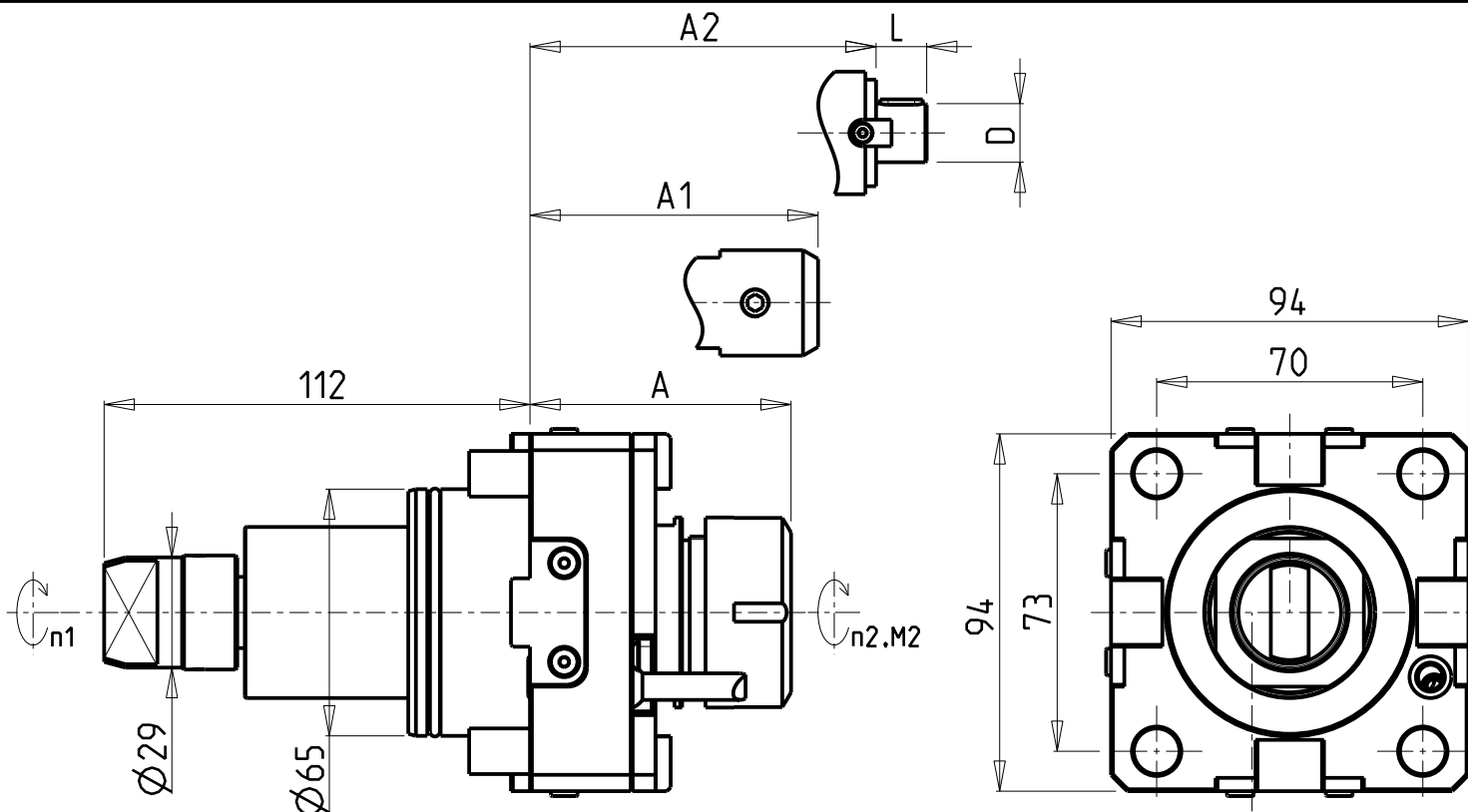

- Chiave inclusa
- Key included
- Schluessel inbegriffen

Cod. MT	Mandrino Spindle Spindel	I (n1:n2)	RPM max n2	Coppia Max Max Torque Max Drehmoment M2 (Nm)	Lubrificazione int. Coolant through Innenkuehlung Pmax (bar)	Lubrificazione est. Ext. coolant Aussenkuehlung	A	A1	A2	D	L	CHIAVI NON INCLUSE Keys not included Schluessel nicht einbegriffen	
DW 01540132	ER32	1:1	6000	100	-	X	68.7	-	-	-	-	CHSTER32	OKU0650004
DW 03470232	ER32	1:1	6000	100	70	X	79.2	-	-	-	-	CHSTER32	OKU0650004
DW 01540140	ER40	1:1	6000	100	-	X	71.7	-	-	-	-	CHSTER40	OKU0650004
DW 03470240	ER40	1:1	6000	100	70	X	82.2	-	-	-	-	CHSTER40	OKU0650004
DW 03470825	WELDON 25	1:1	6000	100	70	X	-	72.5	-	-	-	-	OKU0650004
DW 01540827	Ø27x21	1:1	6000	100	70	X	-	-	56.5	27	21	CH_VTCROCE_M12	OKU0650004

DN SOLUTIONS (DOOSAN) BMT 65

MOD: PUMA 300M/MS - V400M - TT2000SY-TT2500SY-TT2500MS - PUMA 2100-2600M/MS/Y/SY (BMT65) - PUMA 3100 M/Y - MX2000ST
MX2500LT/ST/LST - MX2600T-ST - VT 450M/TM - PUMA INVERTURN 3000M - PUMA GT3100 M - SMX2600/3100ST - PUMA DNT2100-2600M (BMT65)

MODULO MOTORIZZATO RADIALE MAGGIORATO

Radial reinforced driven tool

Radial angetriebenes Werkzeug vergroessert

Subject to change without notice.

M.T. srl

Via Casino Albini 480
Tel. 0541/956034-957884
Fax 0541/956341
47842 S. GIOVANNI IN M. (RN)
e-mail: mtma@mtmarchetti.com
http://www.mtmarchetti.com



DW 0020-3-01