

ATTENZIONE - ATTENTION - ACHTUNG

- Per lo smontaggio degli utensili utilizzare sempre la chiave di contrasto come indicato nel manuale d'uso.
- For disassembly of the tools use always the contrast key as mentioned in the user instructions.
- Fuer das Abmontieren der Werkzeuge immer den Gegenschlüssel benutzen wie in der Bedienungsanleitung erwaeht.

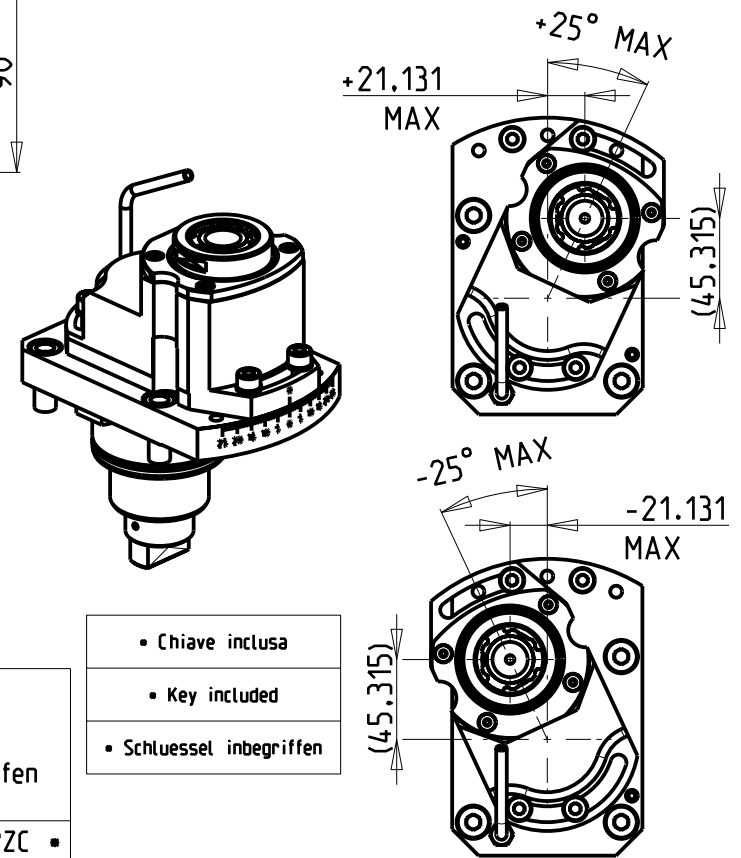

- Chiave inclusa
- Key included
- Schlüssel inbegriffen

Cod. MT	Mandrino Spindle Spindel	I	RPM	Coppia Max Max Torque Max Drehmoment	Reversibile lato mandrino/contromandrino Reversible sub/main spindle side Umkehrbare Spindel-seite/ Gegenspindel-seite	Lubrificazione est. Ext. coolant Ausseukuehlung	CHIAVI NON INCLUSE Keys not included Schluessel nicht einbegriffen		
DW 02980332	ERA32	1:1	6000	100Nm	X	X	CHUB30	CHUB50	CHTAER32ZC *

DN SOLUTIONS (DOOSAN) BMT 75
 MOD: PUMA 400 - PUMA 480M/LM/XLM - PUMA 4100M - PUMA 5100M/Y - V550M - VT 750M/TM - V8300M

MODULO MOTORIZZATO RADIALE DISASSATO 50mm ORIENTABILE ±25°
 Radial ±25° adjustable angle driven tool re-directed by 50mm
 Radial angetriebenes Werkzeug schwenkbar ±25° achsversetzt um 50mm

Subject to change without notice.

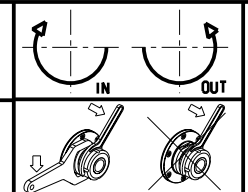

M.T. srl
 Via Casino Albini 480
 Tel. 0541/956034-957884
 Fax 0541/956341
 47842 S. GIOVANNI IN M. (RN)
 e-mail: mtma@mtmarchetti.com
 http://www.mtmarchetti.com



DW 0135-4-00