

ATTENZIONE - ATTENTION - ACHTUNG

- VERIFICARE LE MISURE DI INGOMBRO PER POSSIBILE INTERFERENZA SU ALCUNI MODELLI DI MACCHINE
- Please check the overall sizes for possible interferences on some machine models
- Bitte überprüfen sie das ausmass um mögliche interfeenzen auf einigen maschinen modellen zu vermeiden

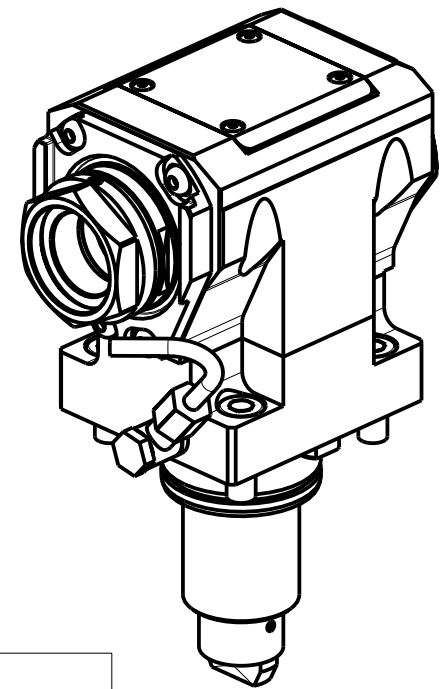

ATTENZIONE: Non si monta su macchina GT2100-2600 M

WARNING: This tool can not be mounted on GT2100-2600 M

ACHTUNG: Werkzeug darf nicht auf GT2100-2600 M montiert werden

PER PORTAUTENSILI MODULARI MTSK-40 VEDI PAG. TBL300-1-40
 FOR MTSK-40 QUIK CHANGE TOOLHOLDERS CLAMPINGS SEE PAGE TBL300-1-40
 FUER MTSK-40 MODULARE WERKZEUGAUFNAHMEN SIEHE SEITE TBL300-1-40

Cod. MT	Mandrino Spindle Spindel	I	RPM	Coppia Max Max Torque Max Drehmoment	Reversibile lato mandrino/contromandrino Reversible sub/main spindle side Umkehrbare Spindel-seite/ Gegenspindel-seite	Lubr.interna Coolant through Innenkuehlung	Lubr.esterna Ext. coolant Aussenkuehlung	B	CHIAVI NON INCLUSE Keys not included Schlüssel nicht einbegriffen	
DW00790140	MTSK-40	1:1	6000	70Nm	X	-	X	54.5	CHUB46	OKU0650004
# DW00790240	MTSK-40	1:1	6000	70Nm	X	P=70bar	X	65.5	CHUB46	OKU0650004

- Chiave inclusa
- Key included
- Schlüssel inbegriffen

DN SOLUTIONS (DOOSAN) BMT 55

MOD: PUMA 230-240M/MS-280LM - PUMA 1500-2000-2100-2500-2600M/MS/Y/SY - LINX 300 M - PUMA H250TM - PUMA TT1500-1800-2100MS/SY/SYY
 PUMA TL2000-2500 (M) - MX1600/2100ST 12ST. - SMX2100ST - PUMA GT2100-2600 M - PUMA QL200HM - LYNX 2600 Y/SY 12ST. - PUMA DNT2100-2600M (BMT55)

MODULO MOTORIZZATO ASSIALE MTSK H=85mm
 Axial MTSK driven tool H=85mm
 Axial MTSK angetriebenes Werkzeug H=85mm

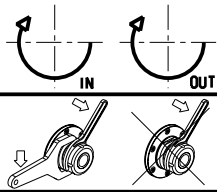

M.T. srl
 Via Casino Albini 480
 Tel. 0541/956034-957884
 Fax 0541/956341
 47842 S. GIOVANNI IN M. (RN)
 e-mail: mtma@tmarchetti.com
 http://www.mtmarchetti.com



DW0150-2-31-K

Subject to change without notice.