

## CUSCINETTI MAGGIORATI PER LAVORAZIONI PESANTI

Reinforced bearings for  
heavy machining

Vergroesserte Lager fuer  
schwerere Bearbeitungen

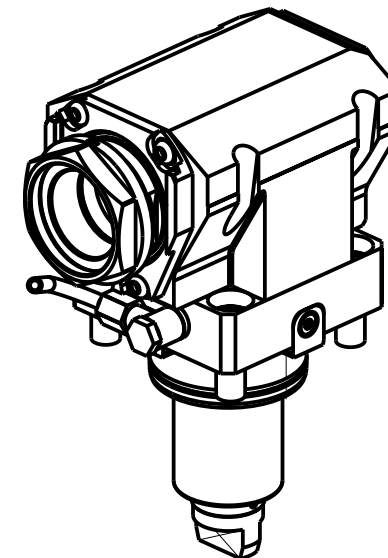
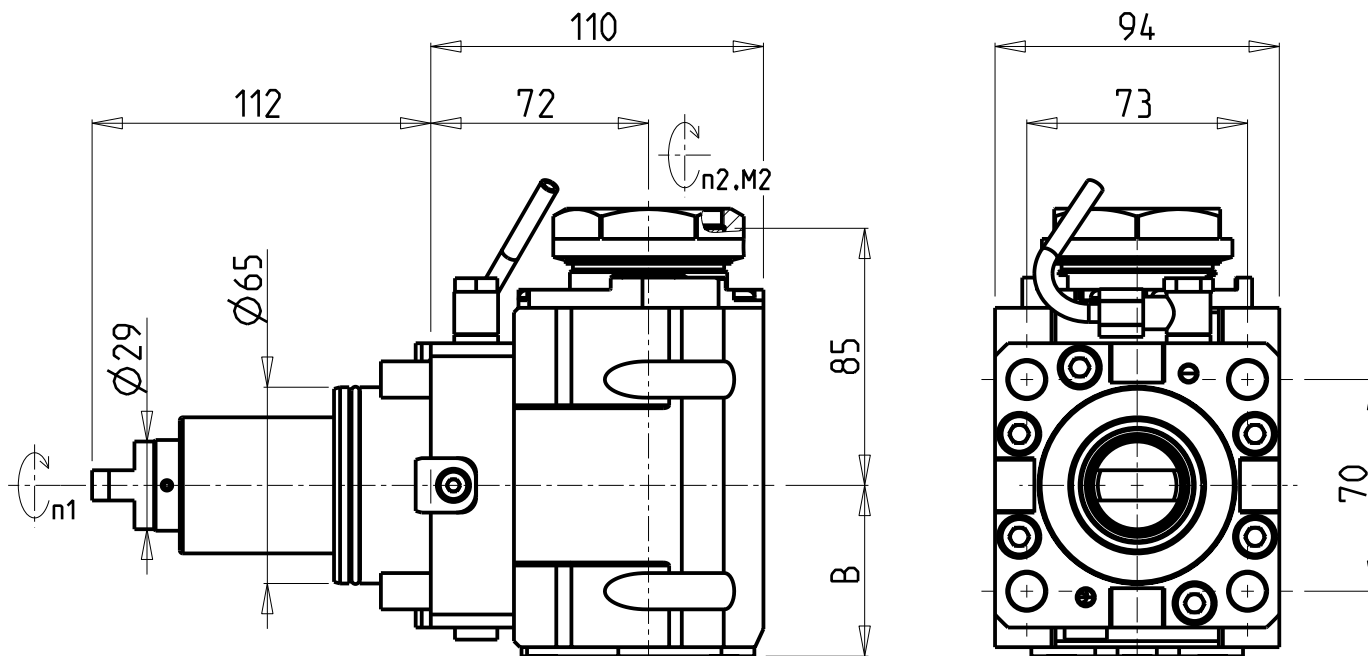

PER PORTAUTENSILI MODULARI MTSK-50 VEDI PAG. TBL300-1-50  
FOR MTSK-50 QUICK CHANGE TOOLHOLDERS CLAMPINGS SEE PAGE TBL300-1-50  
FUER MTSK-50 MODULARE WERKZEUGAUFNAHMEN SIEHE SEITE TBL300-1-50

Cod. MT	Mandrino Spindle Spindel	I (n1:n2)	RPM max n2	Coppia Max Max Torque Max Drehmoment M2 (Nm)	Reversibile lato mandrino/contromandrino Reversible sub/main spindle side Umkehrbare Spindel-seite/Gegenspindel-seite	Lubrificazione int. Coolant through Innenkuehlung Pmax (bar)	Lubr.esterna Ext. coolant Aussenkuehlung	B	CHIAVI NON INCLUSE Keys not included Schluessel nicht einbegriffen
DW02180150	MTSK-50	1:1	6000	110	X	-	X	56.5	CHUB55 OKU0650004 ■
DW02180250	MTSK-50	1:1	6000	110	X	70	X	67.5	CHUB55 OKU0650004 ■

- Chiave inclusa
- Key included
- Schluessel einbegriffen

### DN SOLUTIONS (DOOSAN) BMT 65

MOD: PUMA 300M/MS - V400M - PUMA 2100-2600M/MS/Y/SY (BMT65) - PUMA 3100 M/Y - VT 450M/TM  
PUMA INVERTURN 3000M - PUMA GT3100 M - PUMA DNT2100-2600M (BMT65)

MODULO MOTORIZZATO ASSIALE MAGGIORATO MTSK H=72mm

Axial MTSK reinforced driven tool H=72mm

Axial MTSK angetriebenes Werkzeug vergroessert H=72mm

### M.T. srl

Via Casino Albini 480  
Tel. 0541/956034-957884  
Fax 0541/956341  
47842 S. GIOVANNI IN M. (RN)  
e-mail: mtma@mtmarchetti.com  
http://www.mtmarchetti.com



DW0170-3-10-K

Subject to change without notice.

03/2025