

**CUSCINETTI MAGGIORATI
PER LAVORAZIONI PESANTI**

Reinforced bearings for
heavy machining

Vergroesserte Lager fuer
schwerere Bearbeitungen

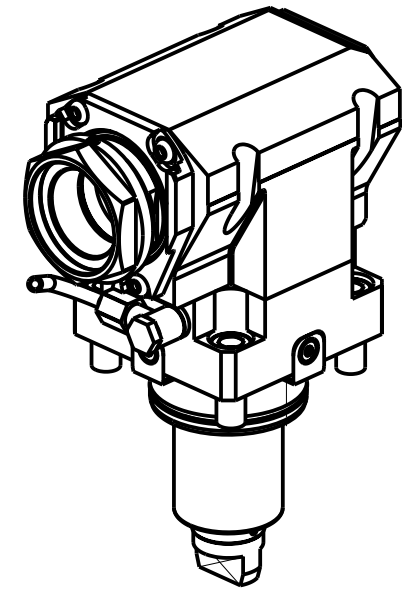

PER PORTAUTENSILI MODULARI MTSK-50 VEDI PAG. TBL300-1-50
FOR MTSK-50 QUICK CHANGE TOOLHOLDERS CLAMPINGS SEE PAGE TBL300-1-50
FUER MTSK-50 MODULARE WERKZEUGAUFNAHMEN SIEHE SEITE TBL300-1-50

Cod. MT	Mandrino Spindel Spindel	I (n1:n2)	RPM max n2	Coppia Max Max Torque Max Drehmoment	Reversibile lato mandrino/contromandrino Reversible sub/main spindle side Umkehrbare Spindel-seite/ Gegenspindel-seite	Lubrificazione int. Coolant through Innenkuehlung	Lubr.esterna Ext. coolant Aussenkuehlung	B	CHIAVI NON INCLUSE Keys not included Schluessel nicht einbegriffen	
				M2 (Nm)	X	Pmax (bar)	X			
DW 02190150	MTSK-50	1:1	6000	110	X	-	X	56.5	CHUB55	OKU0650004 •
DW 02190250	MTSK-50	1:1	6000	110	X	70	X	67.5	CHUB55	OKU0650004 •

- Chiave inclusa
- Key included
- Schluessel inbegriffen

DN SOLUTIONS (DOOSAN) BMT 65

MOD: PUMA 300M/MS - V400M - PUMA 2100-2600M/MS/Y/SY (BMT65) - PUMA 3100 M/Y - VT 450M/TM
PUMA INVERTURN 3000M - PUMA GT3100 M - SMX2600/3100ST - PUMA DNT2100-2600M (BMT65)

MODULO MOTORIZZATO ASSIALE MAGGIORATO MTSK H=85mm

Axial MTSK reinforced driven tool H=85mm

Axial MTSK angetriebenes Werkzeug vergroessert H=85mm

M.T. srl

Via Casino Albini 480
Tel. 0541/956034-957884
Fax 0541/956341
47842 S. GIOVANNI IN M. (RN)
e-mail: mtma@mtmarchetti.com
http://www.mtmarchetti.com



DW 0170-3-20-K

Subject to change without notice.

03/2025