

CUSCINETTI MAGGIORATI PER LAVORAZIONI PESANTI

Reinforced bearings for
heavy machining

Vergroesserte Lager fuer
schwerere Bearbeitungen

ATTENZIONE - ATTENTION - ACHTUNG

- VERIFICARE LE MISURE DI INGOMBRO PER POSSIBILE INTERFERENZA SU ALCUNI MODELLI DI MACCHINE
- Please check the overall sizes for possible interferences on some machine models
- Bitte überprüfen sie das ausmass um mögliche interferenzen auf einigen maschinen modellen zu vermeiden

• Chiave inclusa

• Key included

• Schlüssel inbegriffen

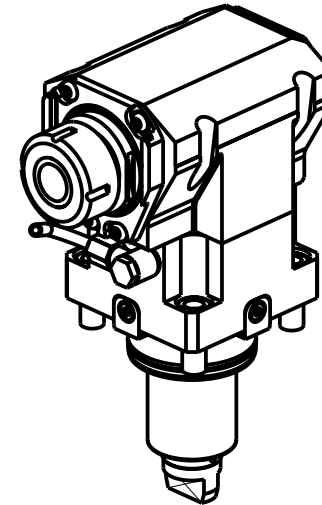
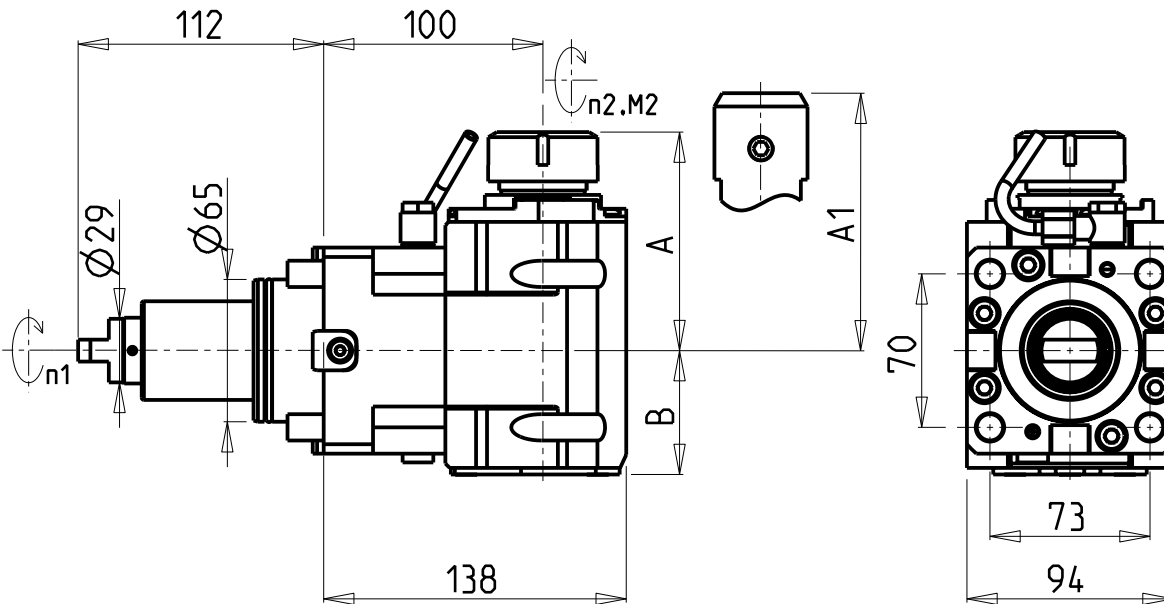

Cod. MT	Mandrino Spindle Spindel	I (n1:n2)	RPM max n2	Coppia Max Max Torque Max Drehmoment M2 (Nm)	Reversibile lato mandrino/contromandrino Reversible sub/main spindle side Umkehrbare Spindel-seite/ Gegenspindel-seite	Lubrificazione int. Coolant through Innenkuehlung Pmax (bar)	Lubr.esterna Ext. coolant Aussenkuehlung	A	A1	B	CHIAVI NON INCLUDE Keys not included Schlüssel nicht einbegriffen	
DW02490132	ER32	1:1	6000	110	X	-	X	99.7	-	56.5	CHSTER32	OKU0650004
DW02490232	ER32	1:1	6000	110	X	70	X	99.7	-	67.5	CHSTER32	OKU0650004
DW02490725	WELDON25	1:1	6000	110	X	-	X	-	106	56.5	-	-
DW02490825	WELDON25	1:1	6000	110	X	70	X	-	106	67.5	-	-

DN SOLUTIONS (DOOSAN) BMT 65

MOD: PUMA 300M/MS - V400M - TT2000SY-TT2500SY-TT2500MS - PUMA 2100-2600M/MS/Y/SY (BMT65) - PUMA 3100 M/Y
MX2000ST - MX2500LT/ST/LST - MX2600T-ST - VT 450M/TM - PUMA INVERTURN 3000M - PUMA GT3100 M - SMX2600/3100ST

MODULO MOTORIZZATO ASSIALE MAGGIORATO H=100mm

Axial reinforced driven tool H=100mm

Axial angetriebenes Werkzeug vergroessert H=100mm

Subject to change without notice.

M.T. srl

Via Casino Albini 480
Tel. 0541/956034-957884
Fax 0541/956341
47842 S. GIOVANNI IN M. (RN)
e-mail: mtma@mtmarchetti.com
http://www.mtmarchetti.com



DW0170-3-30