

**CUSCINETTI MAGGIORATI
PER LAVORAZIONI PESANTI**

Reinforced bearings for
heavy machining

Vergroesserte Lager fuer
schwerere Bearbeitungen

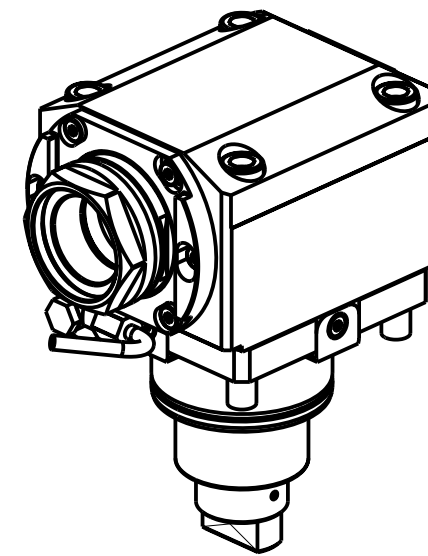

ATTENZIONE: Non si monta su macchina V8300M
WARNING: This tool can not be mounted on V8300M
ACHTUNG: Werkzeug darf nicht auf V8300M montiert werden

PER PORTAUTENSILI MODULARI MTSK-50 VEDI PAG. TBL300-1-50
FOR MTSK-50 QUIK CHANGE TOOLHOLDERS CLAMPINGS SEE PAGE TBL300-1-50
FUER MTSK-50 MODULARE WERKZEUGAUFNAHMEN SIEHE SEITE TBL300-1-50

- Chiave inclusa
- Key included
- Schluessel inbegriffen

Cod. MT	Mandrino Spindle Spindel	I	RPM	Coppia Max Max Torque Max Drehmoment	Reversibile lato mandrino/contromandrino Reversible sub/main spindle side Umkehrbare Spindel-seite/ Gegenspindel-seite	Lubr.interna Coolant through Innenkuehlung	Lubr.esterna Ext. coolant Aussenkuehlung	B	CHIAVI NON INCLUDE Keys not included Schluessel nicht einbegriffen	
DW02140150	MTSK-50	1:1	6000	140Nm	X	-	X	64	CHUB55	OKU0430007 •
# DW02140250	MTSK-50	1:1	6000	140Nm	X	P=70bar	X	76.5	CHUB55	OKU0430007 •

DN SOLUTIONS (DOOSAN) BMT 75
MOD: PUMA 400 - PUMA 480M/LM/XLM - PUMA 4100M - PUMA 5100M/Y - V550M - V8300M

MODULO MOTORIZZATO ASSIALE MAGGIORATO MTSK H=60mm
Axial MTSK reinforced driven tool H=60mm
Axial MTSK angetriebenes Werkzeug vergroessert H=60mm

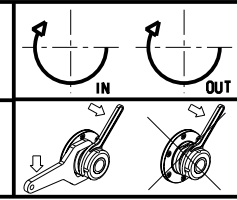

M.T. srl
Via Casino Albini 480
Tel. 0541/956034-957884
Fax 0541/956341
47842 S. GIOVANNI IN M. (RN)
e-mail: mtma@mtmarchetti.com
http://www.mtmarchetti.com



DW0170-4-10-K

Subject to change without notice.