

**ATTENZIONE - ATTENTION - ACHTUNG**

- VERIFICARE LE MISURE DI INGOMBRO PER POSSIBILE INTERFERENZA SU ALCUNI MODELLI DI MACCHINE
- Please check the overall sizes for possible interferences on some machine models
- Bitte überprüfen sie das ausmass um mögliche interferenzen auf einigen maschinen modellen zu vermeiden

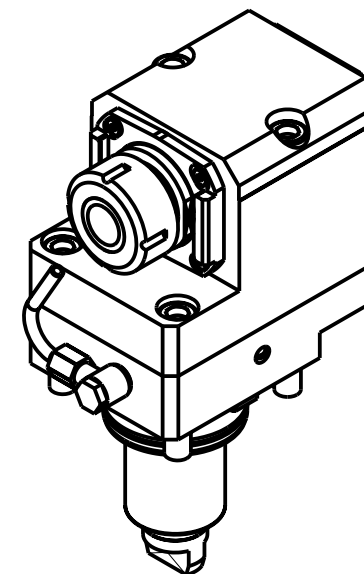
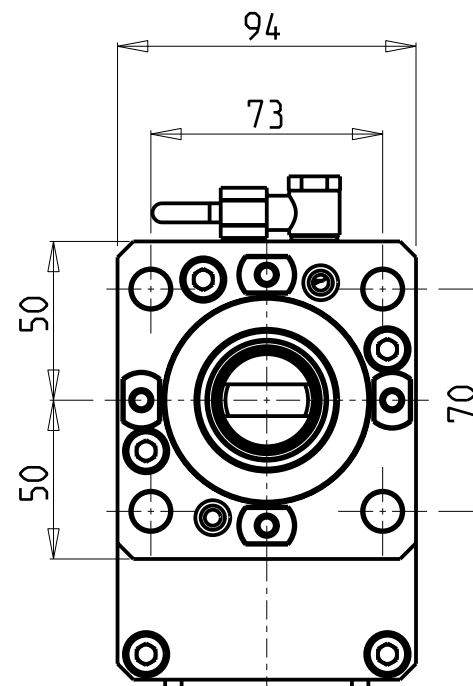
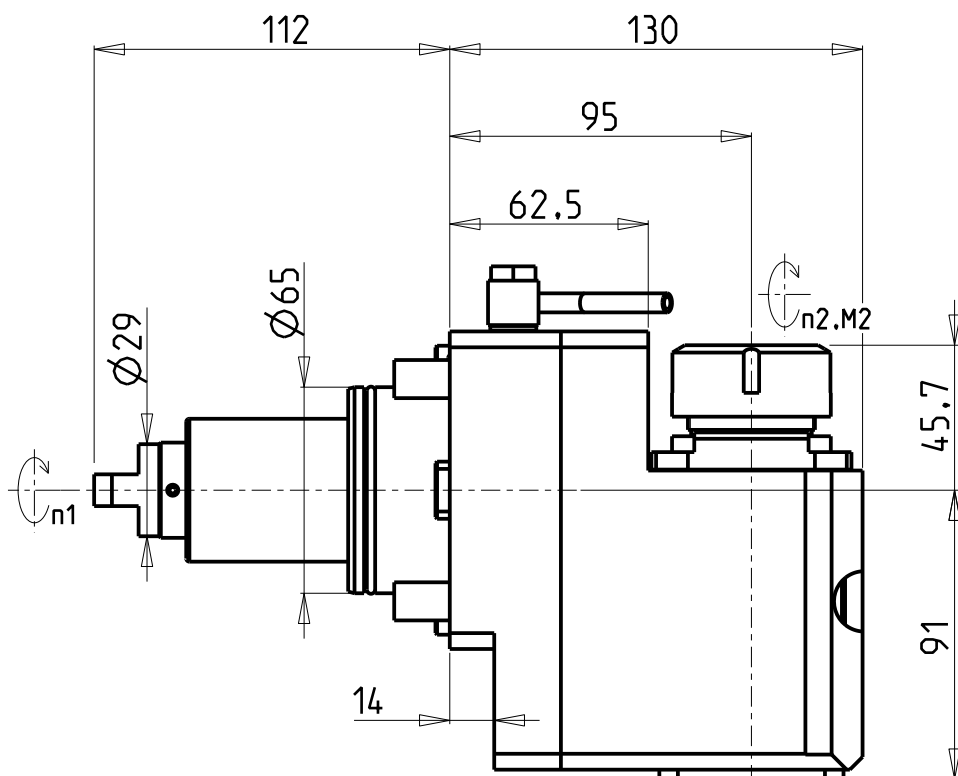

Cod. MT	Mandrino Spindle Spindel	I (n1:n2)	RPM max n2	Coppia Max Max Torque Max Drehmoment M2 (Nm)	Reversibile lato mandrino/contromandrino Reversible sub/main spindle side Umkehrbare Spindel-seite/ Gegenspindel-seite	Lubrificazione est. Ext. coolant Auslenkuehlung	CHIAVI NON INCLUSE Keys not included Schlüssel nicht einbegriffen	
DW 02570132	ER32	1:1	6000	70	X	X	CHSTER32	MNZ0410005 *

- Chiave inclusa
- Key included
- Schlüssel inbegriffen

**DN SOLUTIONS (DOOSAN) BMT 65**

MOD: PUMA 300M/MS - V400M - TT2000SY-TT2500SY-TT2500MS - PUMA 2100-2600M/MS/Y/SY (BMT65) - PUMA 3100 M/Y  
MX2000ST - MX2500LT/ST/LST - VT 450M/TM - PUMA INVERTURN 3000M - PUMA GT3100 M - SMX2600/3100ST

MODULO MOTORIZZATO ASSIALE ARRETRATO H=95mm

Axial rear-set driven tool H=95mm

Axial angetriebenes Werkzeug zurueckversetzt H=95mm

Subject to change without notice.

**M.T. srl**

Via Casino Albini 480  
Tel. 0541/956034-957884  
Fax 0541/956341  
47842 S. GIOVANNI IN M. (RN)  
e-mail: mtma@mtmarchetti.com  
http://www.mtmarchetti.com



DW 0180-3-25