

ATTENZIONE - ATTENTION - ACHTUNG

- Per lo smontaggio degli utensili utilizzare sempre la chiave di contrasto come indicato nel manuale d'uso.
- For disassembly of the tools use always the contrast key as mentioned in the user instructions.
- Fuer das Abmontieren der Werkzeuge immer den Gegenschlüssel benutzen wie in der Bedienungsanleitung erwäehnt.

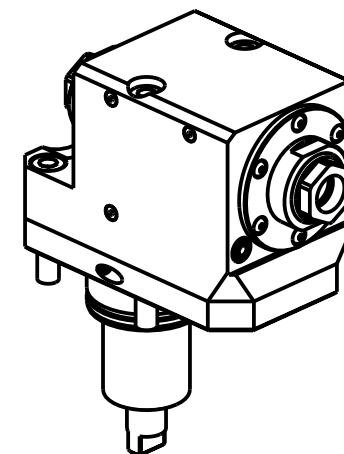
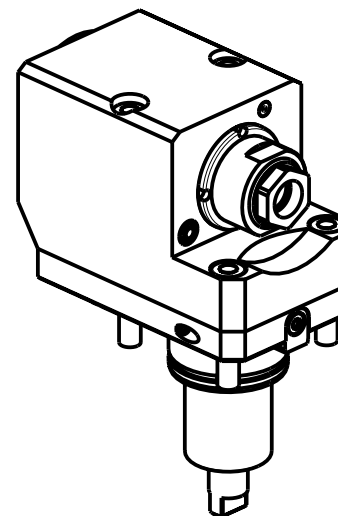

Cod. MT	Mandrino Spindle Spindel	I	RPM	Coppia Max Max Torque Max Drehmoment	Reversibile lato mandrino/contromandrino Reversible sub/main spindle side Umkehrbare Spindel-seite/ Gegen-spindel-seite	Lubrificazione est. Ext. coolant Aus-senkuehlung	CHIAVI NON INCLUSE Keys not included Schluessel nicht inbegriffen	
0632525	ERA25+ERA25	1:1	6000	50Nm	X	X	CHUB27	CHUB38

DN SOLUTIONS (DOOSAN) BMT 55

MOD: PUMA 230-240M/MS-280LM - PUMA 1500-2000-2100-2500-2600M/MS/Y/SY - LINX 300 M
 PUMA 2100-2600Y/SY 16ST. - TL2000-2500 (M) - LYNX 2600 Y/SY 12ST./16ST.

MODULO MOTORIZZATO ASSIALE ARRETRATO BISPORGENTE

Axial opposite face rear-set driven tool

Axial angetriebenes Werkzeug zurueckversetzt halb vorspringend

Subject to change without notice.

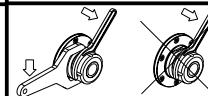

M.T. srl

Via Casino Albini 480
 Tel. 0541/956034-957884
 Fax 0541/956341
 47842 S. GIOVANNI IN M. (RN)
 e-mail: mtma@mtmarchetti.com
 http://www.mtmarchetti.com



DW 0243-2-10