

ATTENZIONE - ATTENTION - ACHTUNG

- Per lo smontaggio degli utensili utilizzare sempre la chiave di contrasto come indicato nel manuale d'uso.
- For disassembly of the tools use always the contrast key as mentioned in the user instructions.
- Fuer das Abmontieren der Werkzeuge immer den Gegenschlüssel benutzen wie in der Bedienungsanleitung erwäehnt.

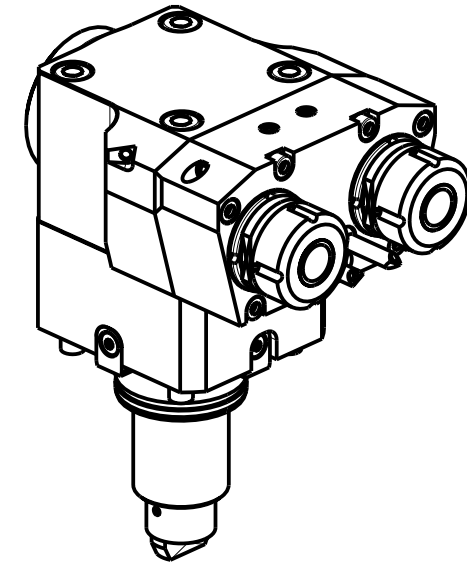
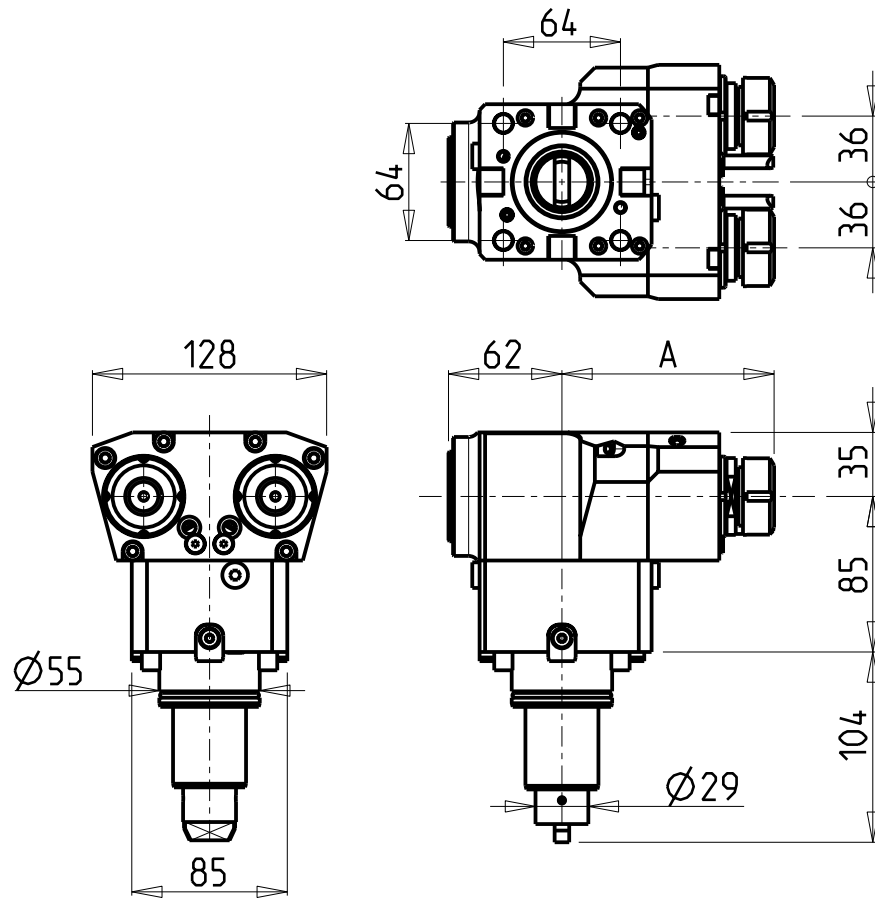

Cod. MT	Mandrino Spindle Spindel	I	RPM	Coppia Max Max Torque Max Drehmoment	Reversibile lato mandrino/contromandrino Reversible sub/main spindle side Umkehrbare Spindel-seite/ Gegenspindel-seite	Lubrificazione est. Ext. coolant Aussenkuehlung	A	CHIAVI NON INCLUSE Keys not included Schluessel nicht einbegriffen	
								CHMNER16	CHUB17
DW00952216	ER16	1:2	12000	20Nm	X	X	115	CHMNER16	CHUB17
DW00952225	ER25	1:2	12000	20Nm	X	X	115.96	CHSTER25	CHUB36

DN SOLUTIONS (DOOSAN) BMT 55
 MOD: PUMA 1500-2000-2100-2500-2600M/MS/Y/SY - PUMA TT1500-1800-2100MS/SY/SYY - PUMA TL2000-2500 (M)
 LYNX 2600 Y/SY 12ST.

MODULO MOTORIZZATO ASSIALE 2 USCITE IN Y MOLTIPLICATO I=1:2 H=85mm
 Axial geared-up I=1:2 single side twin head driven tool in Y H=85mm
 Axial angetriebenes Werkzeug 2 Ausgaenge in Y uebersetzt I=1:2 H=85mm

Subject to change without notice.

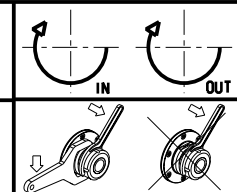

M.T. srl
 Via Casino Albini 480
 Tel. 0541/956034-957884
 Fax 0541/956341
 47842 S. GIOVANNI IN M. (RN)
 e-mail: mtma@mtmarchetti.com
 http://www.mtmarchetti.com



DW 0261-2-30