

INCLINAZIONE
REGOLABILE ±30°

ATTENZIONE - ATTENTION - ACHTUNG

- VERIFICARE LE MISURE DI INGOMBRO PER POSSIBILE INTERFERENZA SU ALCUNI MODELLI DI MACCHINE
- Please check the overall sizes for possible interferences on some machine models
- Bitte überprüfen sie das ausmass um mögliche interferenzen auf einigen maschinen modellen zu vermeiden

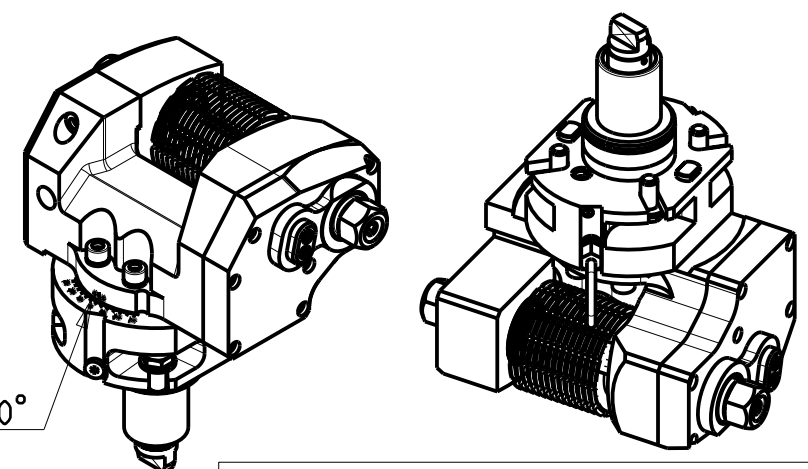

-LA FUNZIONE DI POLIGONATURA/DENTATURA DEVE ESSERE INSTALLATA SULLA MACCHINA
-POLYGON CUTTING/GEAR HOBGING FUNCTION MUST BE INSTALLED ON THE MACHINE
-DIE FUNKTION FÜR POLYGON-BZW .VERZÄHNUNGSFRÄSEN MUSS AUF DER MASCHINE FREIGESCHALTET WERDEN

DOTAZIONI - SUPPLIED WITH - AUSSTATTUNG

| | |
|-----------|-----------------------------|
| mm / inch | - N°1 ALBERO + DISTANZIALI |
| | - N°1 SHAFT + SPACER |
| | - N°1 DORN + ABSTANDSSTUECK |

PER ALBERI E DISTANZIALI VEDI PAG. TBL250-1-00
FOR SHAFT END SPACER SEE PAGE TBL250-1-00
FUER DORN UND ABSTANDSSTUECK SEITE TBL250-1-00

| Cod. MT | I (n1:n2) | RPM max n2 | Coppia Max Max Torque Max Drehmoment M2 (Nm) | Lubrificazione est. Ext. coolant Aussenkuehlung | D (mm) | D (Inch) | CHIAVI INCLUSE Keys included Schluessel inbegriffen | | | |
|------------|--------------|------------------|---|---|-------------|----------------|---|--------|---------|----------------------|
| | | | | | | | CHUB30 | CHUB19 | CHESL08 | CHUB24 (Ø16 / Ø3/4") |
| DW00031100 | 1:1 | 6000 | 90 | X | 16-22-27-32 | 3/4"-1"-1 1/4" | CHUB30 | CHUB19 | CHESL08 | CHUB24 (Ø16 / Ø3/4") |
| DW00032100 | 2:1 | 3000 | 110 | X | 16-22-27-32 | 3/4"-1"-1 1/4" | CHUB30 | CHUB19 | CHESL08 | CHUB24 (Ø16 / Ø3/4") |

DN SOLUTIONS (DOOSAN) BMT 65
 MOD: PUMA 300M/MS - V400M - TT2000SY-TT2500SY-TT2500MS - PUMA 2100-2600M/MS/Y/SY (BMT65) - PUMA 3100 M/Y
 VT 450M/TM - PUMA GT3100 M - SMX2600/3100ST - PUMA DNT2100-2600M (BMT65)
MODULO MOTORIZZATO PORTACREATORE MAGGIORATO
 Reinforced driven gear hobber
 Angetriebenes Zahnradwaeltzraes-Werkzeug vergroessert

M.T. srl
 Via Casino Albini 480
 Tel. 0541/956034-957884
 Fax 0541/956341
 47842 S. GIOVANNI IN M. (RN)
 e-mail: mtma@mtmarchetti.com
 http://www.mtmarchetti.com



DW0340-3-60

Subject to change without notice.