

## CUSCINETTI MAGGIORATI PER LAVORAZIONI PESANTI

Reinforced bearings for  
heavy machining

Vergroesserte Lager fuer  
schwerere Bearbeitungen

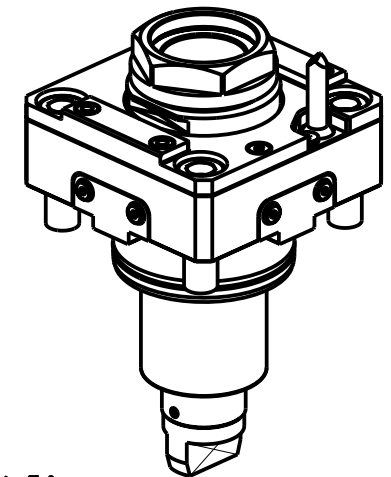
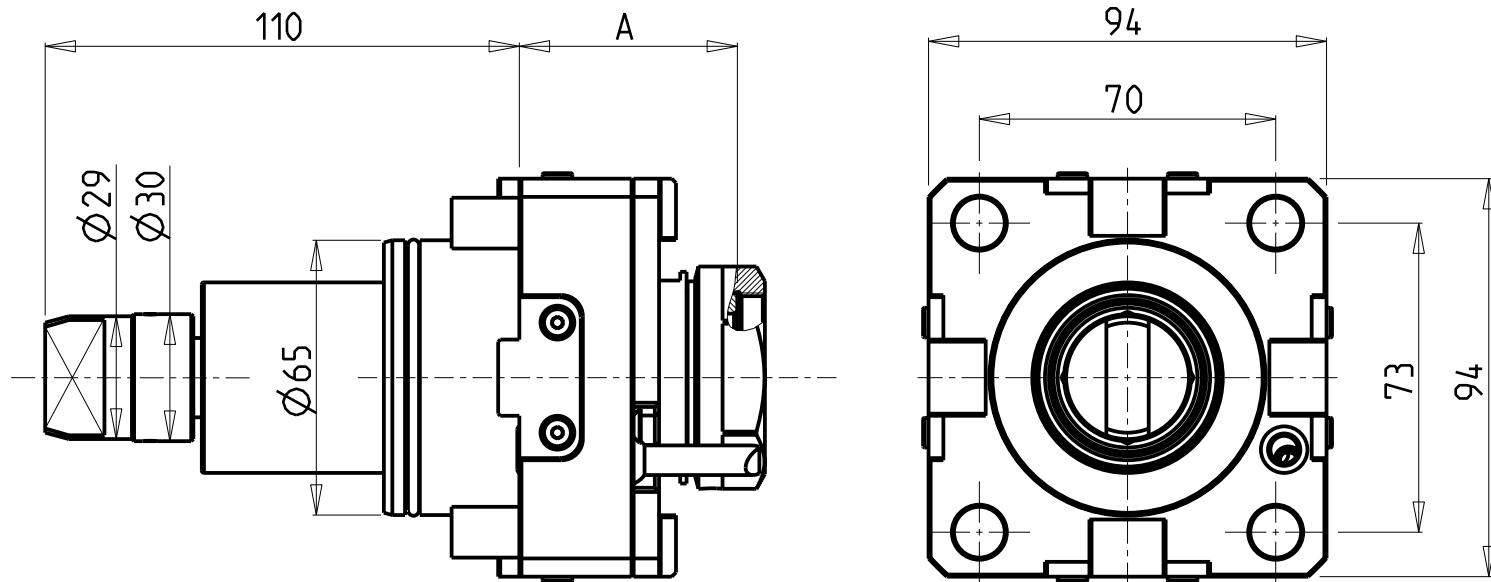

PER PORTAUTENSILI MODULARI MTSK-40 VEDI PAG. TBL300-1-40 E PER MTSK-50 VEDI PAG. TBL300-1-50  
FOR MTSK-40 QUIK CHANGE TOOLHOLDERS CLAMPINGS SEE PAGE TBL300-1-40 AND FOR MTSK-50 SEE PAGE TBL300-1-50  
FUER MTSK-40 MODULARE WERKZEUGAUFNAHMEN SIEHE SEITE TBL300-1-40 UND FUER MTSK-50 SIEHE SEITE TBL300-1-50

Cod. MT	Mandrino Spindle Spindel	I	RPM	Coppia Max Max Torque Max Drehmoment	Lubrificazione int. Coolant through Innenkuehlung	Lubrificazione est. Ext. coolant Aussenkuehlung	A	CHIAVI NON INCLUSE Keys not included Schlüssel nicht einbegriffen	
EMG0060140	MTSK-40	1:1	6000	100Nm	-	X	51.5	CHUB46	OKU0650004
EMG0160240	MTSK-40	1:1	6000	100Nm	P=70bar	X	62.5	CHUB46	OKU0650004
EMG0060150	MTSK-50	1:1	6000	100Nm	-	X	51.5	CHUB55	OKU0650004
EMG0160250	MTSK-50	1:1	6000	100Nm	P=70bar	X	62.5	CHUB55	OKU0650004

- Chiave inclusa
- Key included
- Schlüssel inbegriffen

EMAG

VL6 - VM9 - VMC450 - VM9-4 - VMC450-4 (BMT65)

MODULO MOTORIZZATO RADIALE MAGGIORATO MTSK  
Radial MTSK reinforced driven tool  
Radial MTSK angetriebenes Werkzeug vergroessert

Subject to change without notice.

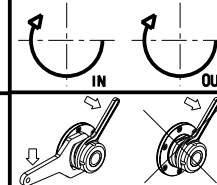

**M.T. srl**

Via Casino Albini 480  
Tel. 0541/956034-957884  
Fax 0541/956341  
47842 S. GIOVANNI IN M. (RN)  
e-mail: mtma@mtmarchetti.com  
http://www.mtmarchetti.com



PAGINA EMG020-3-00-K

09/2023