

CUSCINETTI MAGGIORATI PER LAVORAZIONI PESANTI

Reinforced bearings for
heavy machining

Vergroesserte Lager fuer
schwerere Bearbeitungen

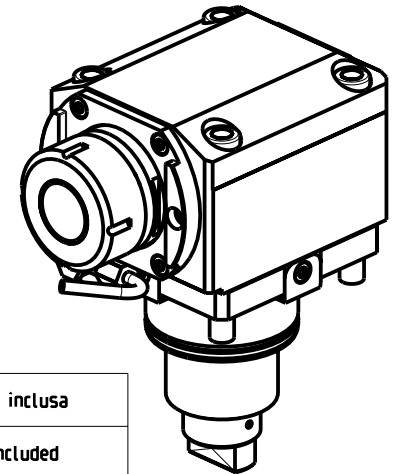

- Chiave inclusa
- Key included
- Schluessel inbegriffen

Cod. MT	Mandrino Spindle Spindel	I	RPM	Coppia Max Max Torque Max Drehmoment	Lubrificazione int. Coolant through Innenkuehlung	Lubrificazione est. Ext. coolant Aussenkuehlung	A	A1	A2	B	D	L	CHIAVI NON INCLUSE Keys not included Schluessel nicht einbegriffen	
EMG0210140	ER40	1:1	6000	140Nm	-	X	109.7	-	-	64	-	-	CHSTER40	OKU0430007 *
EMG0210240	ER40	1:1	6000	140Nm	P=70bar	X	109.7	-	-	76.5	-	-	CHSTER40	OKU0430007 *
EMG0210725	WELDON 25	1:1	6000	140Nm	-	X	-	109.5	-	64	-	-	-	-
EMG0210825	WELDON 25	1:1	6000	140Nm	P=70bar	X	-	109.5	-	76.5	-	-	-	-
EMG0210522	Ø22x19	1:1	6000	140Nm	-	X	-	-	89	64	22	19	CH_VTCROCE_M10 *	OKU0430007 *

EMAG

MOD: VL8 - VL10 - VLC500 - VM12 - VMC600 (BMT75)

MODULO MOTORIZZATO ASSIALE MAGGIORATO H=60mm

Axial reinforced driven tool H=60mm

Axial angetriebenes Werkzeug vergroessert H=60mm

Subject to change without notice.

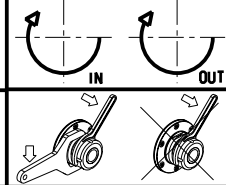

M.T. srl

Via Casino Albini 480
Tel. 0541/956034-957884

Fax 0541/956341

47842 S. GIOVANNI IN M. (RN)

e-mail: mtma@mtmarchetti.com

http://www.mtmarchetti.com



PAGINA EMG170-4-10