

ATTENZIONE - ATTENTION - ACHTUNG

- Per lo smontaggio degli utensili utilizzare sempre la chiave di contrasto come indicato nel manuale d'uso.
- For disassembly of the tools use always the contrast key as mentioned in the user instructions.
- Fuer das Abmontieren der Werkzeuge immer den Gegenschlüssel benutzen wie in der Bedienungsanleitung erwaeht.

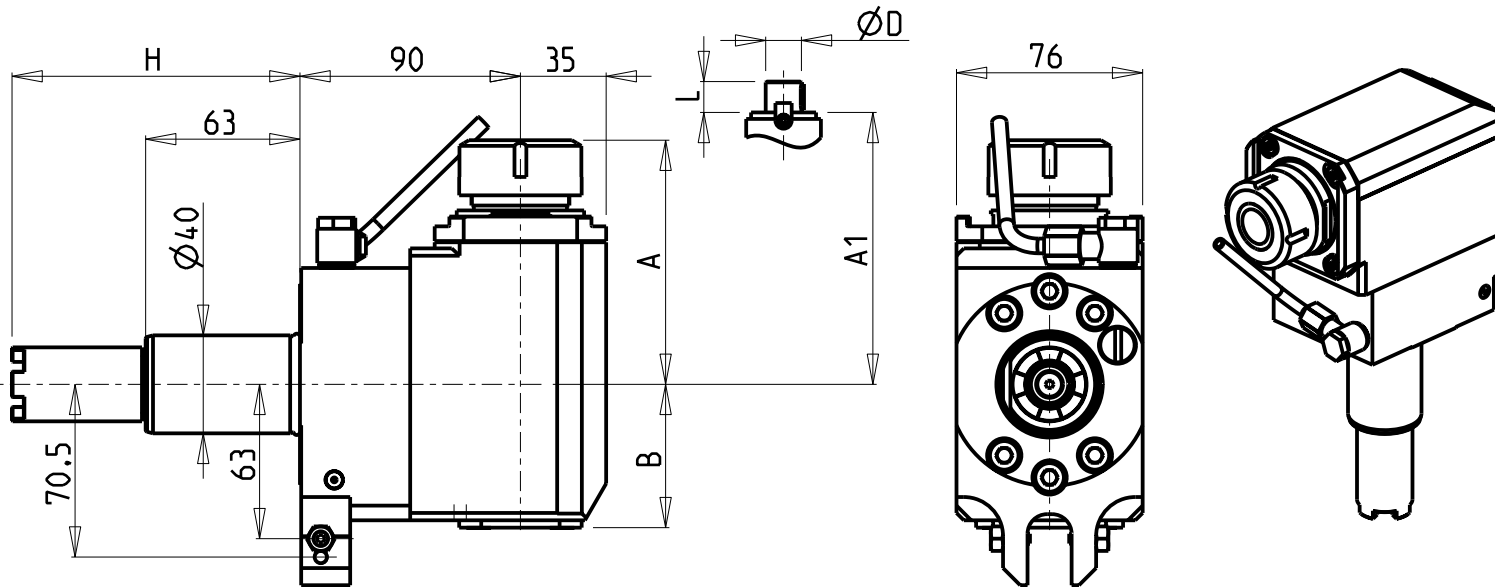

- Chiave inclusa
- Key included
- Schlüssel inbegriffen

Cod. MT	Mandrino Spindel Spindel	I	RPM	Coppia Max Max Torque Max Drehmoment	Lubrificazione int. Coolant through Innenkuhlung	Lubrificazione est. Ext. coolant Aussenkuhlung	A	A1	B	H	Tipo Torretta Turret type Revolver typ	CHIAVI NON INCLUSE Keys not included Schluessel nicht einbegriffen	
HAS0140132	ER32	1:1	6000	70Nm	-	X	99.7	-	58.5	117.55	VDI STANDARD / HYBRID TURRET	OKU0650004	CHSTER32
HAS0140232	ER32	1:1	6000	70Nm	P=70bar	X	99.7	-	69.5	117.55	VDI STANDARD / HYBRID TURRET	OKU0650004	CHSTER32
HAS0140140	ER40	1:1	6000	70Nm	-	X	103.7	-	58.5	117.55	VDI STANDARD / HYBRID TURRET	OKU0650004	CHSTER40
HAS0140240	ER40	1:1	6000	70Nm	P=70bar	X	103.7	-	69.5	117.55	VDI STANDARD / HYBRID TURRET	OKU0650004	CHSTER40
HAS0142219	Ø22x19	1:1	6000	70Nm	-	X	-	78.5	58.5	117.55	VDI STANDARD / HYBRID TURRET	CHUB41	CH_VTCROCE_M10
HAS0142721	Ø27x21	1:1	6000	70Nm	-	X	-	78.5	58.5	117.55	VDI STANDARD / HYBRID TURRET	CHUB41	CH_VTCROCE_M12

HAAS
 MOD: ST10/15/20/25/30/35 - DS30 - TL15/25

MODULO MOTORIZZATO RADIALE VDI40
 Radial driven tool VDI40
 Radial angetriebenes Werkzeug VDI40

Subject to change without notice.

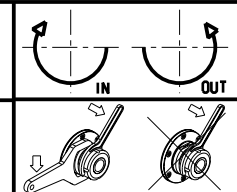

M.T. srl
 Via Casino Albini 480
 Tel. 0541/956034-957884
 Fax 0541/956341
 47842 S. GIOVANNI IN M. (RN)
 e-mail: mtma@mtmarchetti.com
 http://www.mtmarchetti.com



HAS013-3-20