

CUSCINETTI MAGGIORATI PER LAVORAZIONI PESANTI

Reinforced bearings for
heavy machining

Vergroesserte Lager fuer
schwerere Bearbeitungen

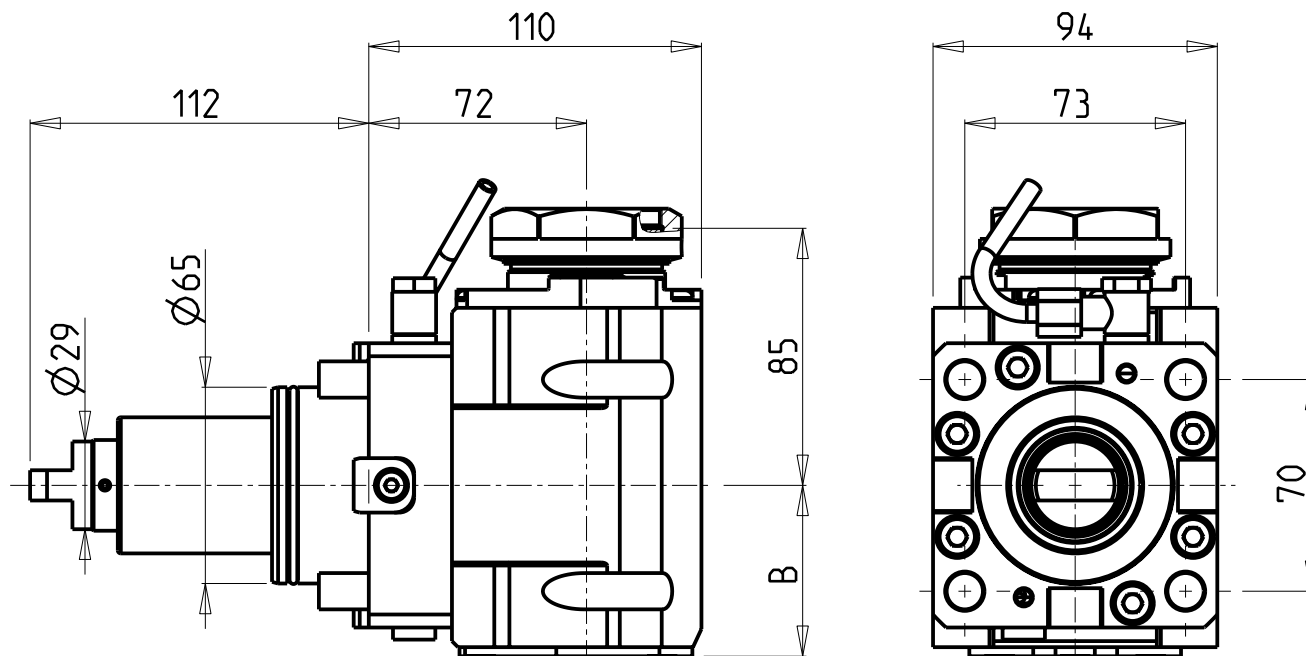
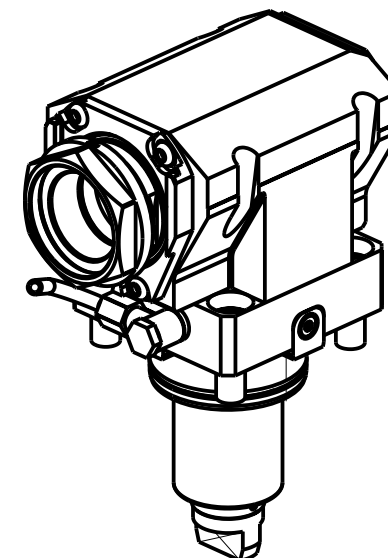

PER PORTAUTENSILI MODULARI MTSK-50 VEDI PAG. TBL300-1-50
FOR MTSK-50 QUICK CHANGE TOOLHOLDERS CLAMPINGS SEE PAGE TBL300-1-50
FUER MTSK-50 MODULARE WERKZEUGAUFNAHMEN SIEHE SEITE TBL300-1-50

Cod. MT	Mandrino Spindel Spindel	I	RPM	Coppia Max Max Torque Max Drehmoment	Reversibile lato mandrino/contromandrino Reversible sub/main spindle side Umkehrbare Spindel-seite/Gegenspindel-seite	Lubr.interna Coolant through Innenkuehlung	Lubr.esterna Ext. coolant Aussenkuehlung	B	CHIAVI NON INCLUSE Keys not included Schluessel nicht einbegriffen
DW02180150	MTSK-50	1:1	6000	110Nm	X	-	X	56.5	CHUB55 OKU0650004 *
DW02180250	MTSK-50	1:1	6000	110Nm	X	P=70bar	X	67.5	CHUB55 OKU0650004 *

- Chiave inclusa
- Key included
- Schluessel einbegriffen

HAAS
MOD: ST20/25/28/30/35 (BMT65) - DS30 (BMT65)

MODULO MOTORIZZATO ASSIALE MAGGIORATO MTSK H=72mm
Axial MTSK reinforced driven tool H=72mm
Axial MTSK angetriebenes Werkzeug vergroessert H=72mm

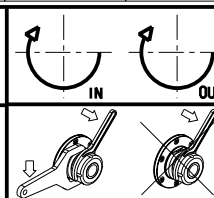

M.T. srl
Via Casino Albini 480
Tel. 0541/956034-957884
Fax 0541/956341
47842 S. GIOVANNI IN M. (RN)
e-mail: mtma@mtmarchetti.com
http://www.mtmarchetti.com



HAS170-4-10-K

Subject to change without notice.

03/2024