

ATTENZIONE - ATTENTION - ACHTUNG

- VERIFICARE LE MISURE DI INGOMBRO PER POSSIBILE INTERFERENZA SU ALCUNI MODELLI DI MACCHINE
- Please check the overall sizes for possible interferences on some machine models
- Bitte überprüfen sie das ausmass um mögliche interferenzen auf einigen maschinen modellen zu vermeiden

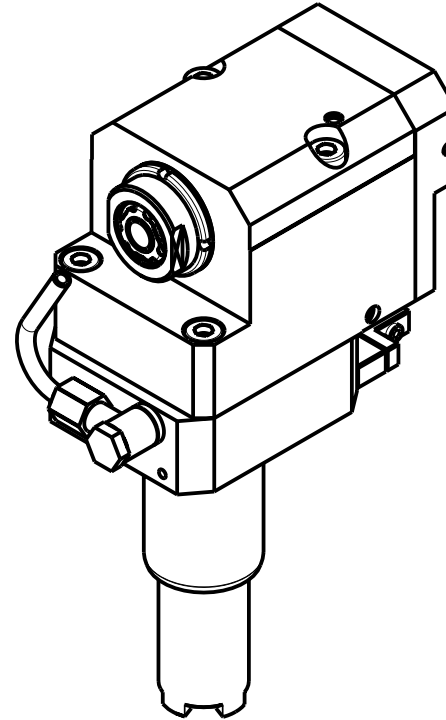
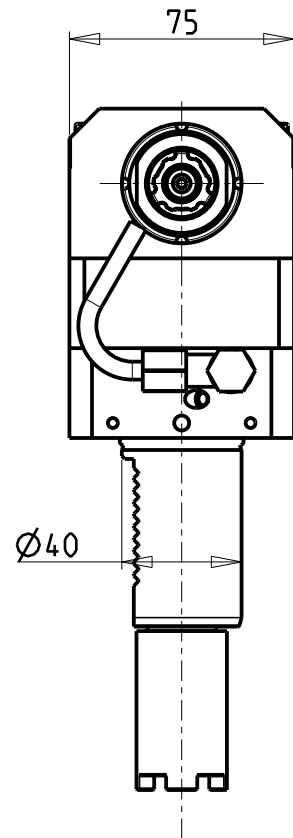
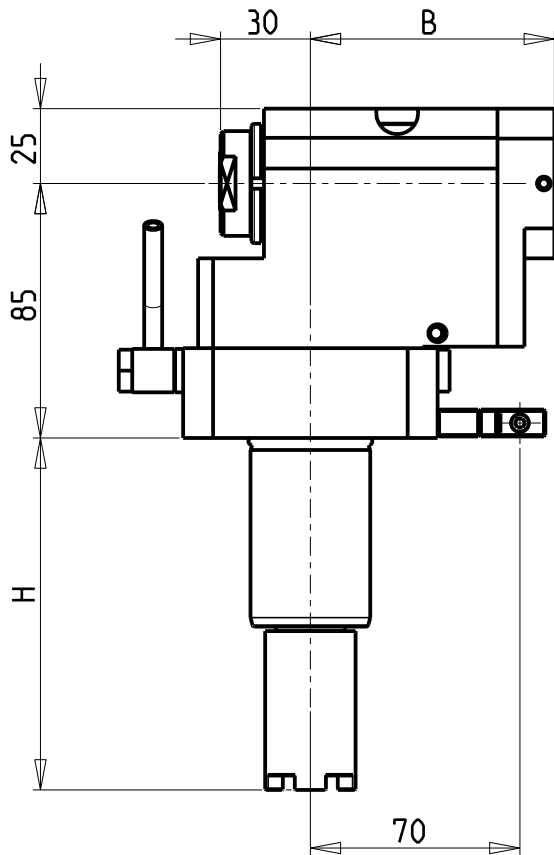

- Chiave inclusa
- Key included
- Schluessel inbegriffen

Cod. MT	Mandrino Spindle Spindel	I	RPM	Coppia Max Max Torque Max Drehmoment	Lubrificazione int. Coolant through Innenkühlung	Lubrificazione est. Ext. coolant Aussenkühlung	B	H	Tipo Torretta Turret Type Revolver Typ	CHIAVI NON INCLUSE Keys not included Schluessel nicht einbegriffen		
HAS0410116	ERA16	1:3	18000	10Nm	-	X	70.5	117.55	VDI STANDARD / HYBRID TURRET	CHUB30	CHUB19_SP3	CHTAER16ZC •
HAS0410216	ERA16	1:3	18000	10Nm	P=70bar	X	83	117.55	VDI STANDARD / HYBRID TURRET	CHUB30	CHUB19_SP3	CHTAER16ZC •

HAAS  
MOD: ST10/15/20/25/30/35 - DS30 - TL15/25

MODULO MOTORIZZATO RADIALE ARRETRATO MOLTIPLICATO I=1:3 VDI40  
Radial geared-up I=1:3 rear-set driven tool VDI40  
Radial angetriebenes Werkzeug uebersetzt I=1:3 zurueckversetzt VDI40

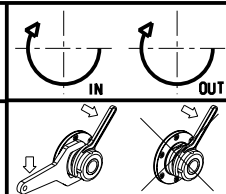

**M.T. srl**  
Via Casino Albini 480  
Tel. 0541/956034-957884  
Fax 0541/956341  
47842 S. GIOVANNI IN M. (RN)  
e-mail: mtma@mtmarchetti.com  
http://www.mtmarchetti.com

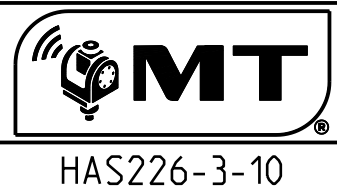

Subject to change without notice.

03/2024