

ATTENZIONE - ATTENTION - ACHTUNG

- VERIFICARE LE MISURE DI INGOMBRO PER POSSIBILE INTERFERENZA SU ALCUNI MODELLI DI MACCHINE
- Please check the overall sizes for possible interferences on some machine models
- Bitte überprüfen sie das ausmass um mögliche interferenzen auf einigen maschinen modellen zu vermeiden

ATTENZIONE - ATTENTION - ACHTUNG

- Per lo smontaggio degli utensili utilizzare sempre la chiave di contrasto come indicato nel manuale d'uso.
- For disassembly of the tools use always the contrast key as mentioned in the user instructions.
- Für das Abmontieren der Werkzeuge immer den Gegenschlüssel benutzen wie in der Bedienungsanleitung erwähnt.

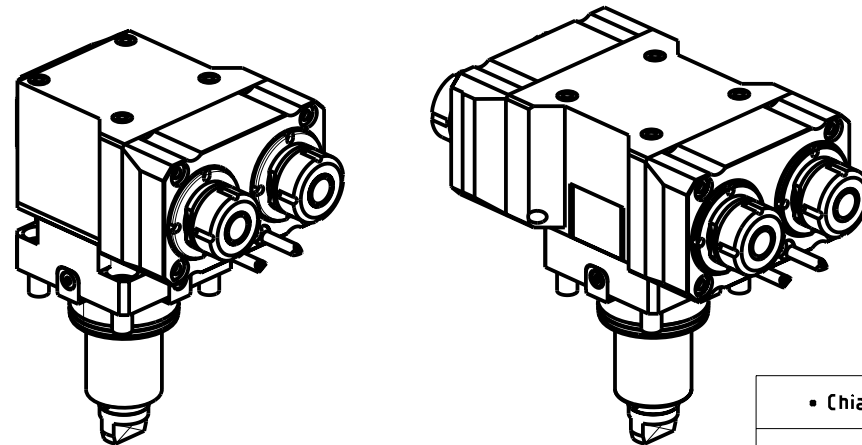

- Chiave inclusa
- Key included
- Schlüssel inbegriffen

Cod. MT	Mandrino Spindle Spindel	I	RPM	Coppia Max Max Torque Max Drehmoment	N°Utensili N°Tools N°Werkzeuge	Reversibile lato mandrino/contromandrino Reversible sub/main spindle side Umkehrbare Spindel-seite/ Gegenspindel-seite	Lubr.interna Coolant through Innenkuehlung	Lubrificazione est. Ext. coolant Aussenkuehlung	A	B	CHIAVI NON INCLUSE Keys not included Schluessel nicht inbegriffen		
DW 01120225	ER25	1:1	6000	40Nm	2	X	-	X	130.46	60	CHUB36	CHSTER25	-
DW 01121225	ER25	1:1	6000	40Nm	2	X	P=70bar	X	150.16	60	CHUB36	CHSTER25	-
DW 01120325	ERA25	1:1	6000	40Nm	2	X	-	X	119	60	CHUB38	CHUB27	CHTAER25ZC
DW 01121325	ERA25	1:1	6000	40Nm	2	X	P=70bar	X	142	60	CHUB38	CHUB27	-
DW 01122225	ER25+ER25	1:1	6000	40Nm	2+2	X	-	X	130.46	125.46	CHUB36	CHSTER25	-
DW 01122325	ERA25+ERA25	1:1	6000	40Nm	2+2	X	-	X	119	114	CHUB38	CHUB27	CHTAER25ZC

HAAS
 MOD: ST20/25/28/30/35 (BMT65) - DS30 (BMT65)

MODULO MOTORIZZATO ASSIALE 2 USCITE IN Y H=72mm
 Axial single side twin head driven tool in Y H=72mm
 Axial angetriebenes Werkzeug 2 Ausgaenge in Y H=72mm

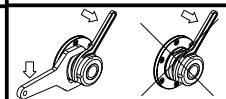

M.T. srl
 Via Casini Albini 480
 Tel. 0541/956034-957884
 Fax 0541/956341
 47842 S. GIOVANNI IN M. (RN)
 e-mail: mtma@mtmarchetti.com
 http://www.mtmarchetti.com



HAS260-4-10

Subject to change without notice.