

30°

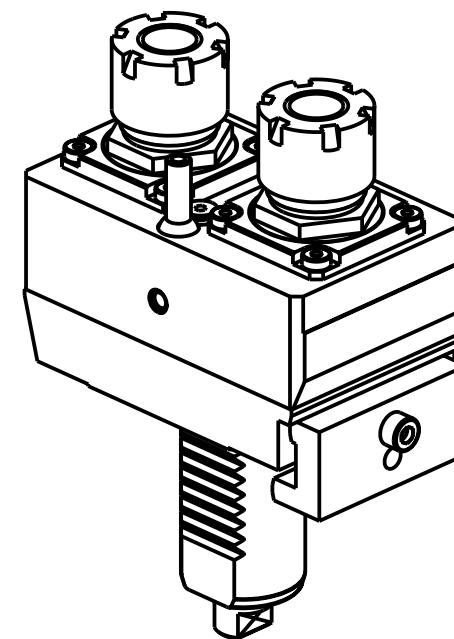
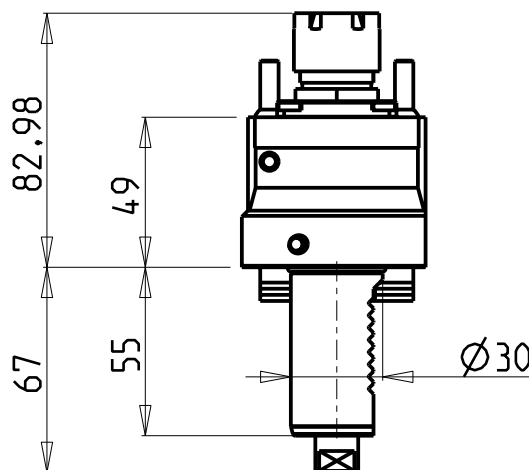
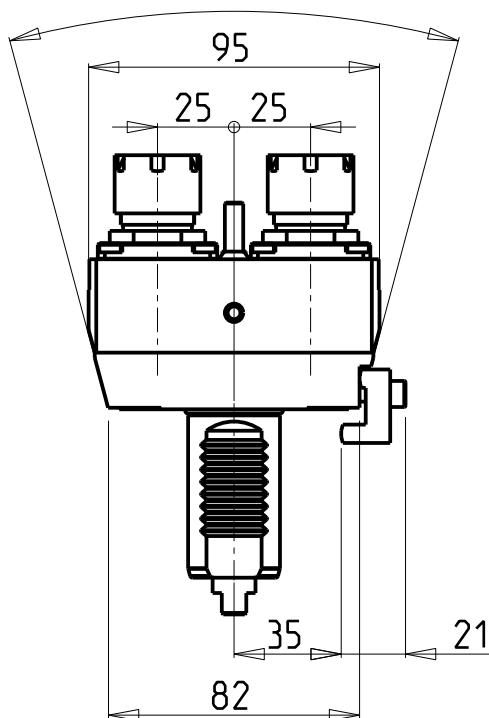

ATTENZIONE - ATTENTION - ACHTUNG

- Per lo smontaggio degli utensili utilizzare sempre la chiave di contrasto come indicato nel manuale d'uso.
- For disassembly of the tools use always the contrast key as mentioned in the user instructions.
- Fuer das Abmontieren der Werkzeuge immer den Gegenschlüssel benutzen wie in der Bedienungsanleitung erwaeht.

Cod. MT	Mandrino Spindle Spindel	I	RPM	Coppia Max Max Torque Max Drehmoment	Lubrificazione est. Ext. coolant Aussenkuehlung	CHIAVI NON INCLUSE Keys not included Schluessel nicht einbegriffen	
HNW0040120	ER20	1:1	6000	25Nm	X	CHUB27	CHMNER20

HANW HA
 MOD: STL32H/35H/38H (Y3) - STL42H/N/NH (Y3) (VDI30)

MODULO MOTORIZZATO ASSIALE 2 USCITE IN Z VDI30
 Axial single side twin head driven tool in Z VDI30
 Axial angetriebenes Werkzeug 2 Ausgaenge in Z VDI30

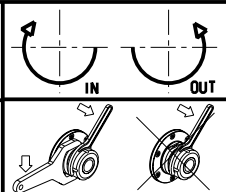

M.T. srl
 Via Casino Albini 480
 Tel. 0541/956034-957884
 Fax 0541/956341
 47842 S. GIOVANNI IN M. (RN)
 e-mail: mtma@mtmarchetti.com
 http://www.mtmarchetti.com



PAGINA HNW 017-1-90

Subject to change without notice.