

ATTENZIONE - ATTENTION - ACHTUNG

- Per lo smontaggio degli utensili utilizzare sempre la chiave di contrasto come indicato nel manuale d'uso.
- For disassembly of the tools use always the contrast key as mentioned in the user instructions.
- Fuer das Abmontieren der Werkzeuge immer den Gegenschlüssel benutzen wie in der Bedienungsanleitung erwaehnt.

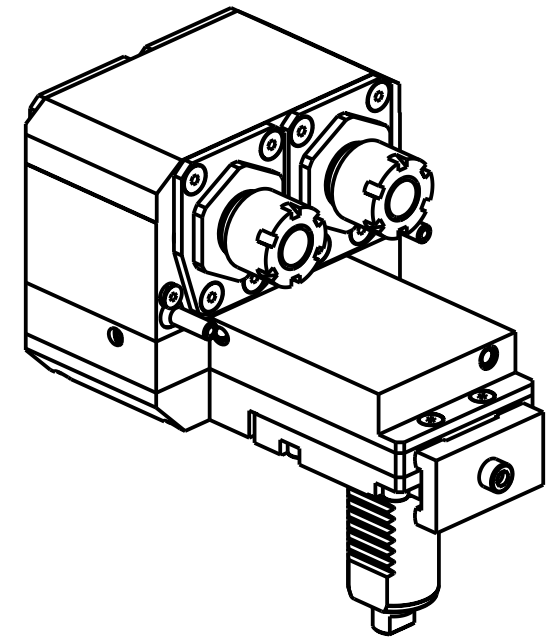
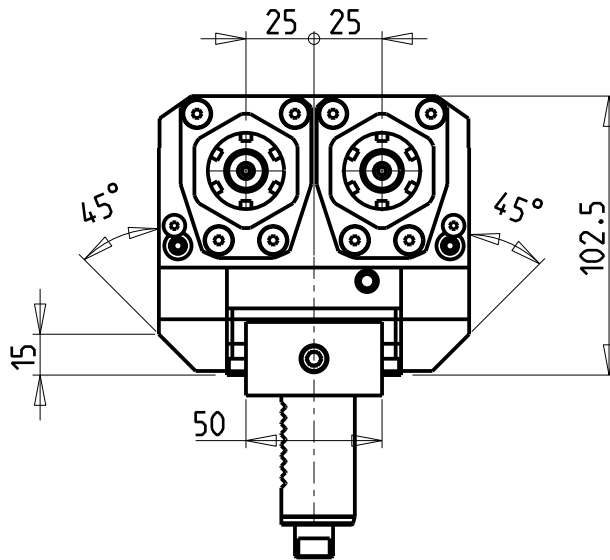
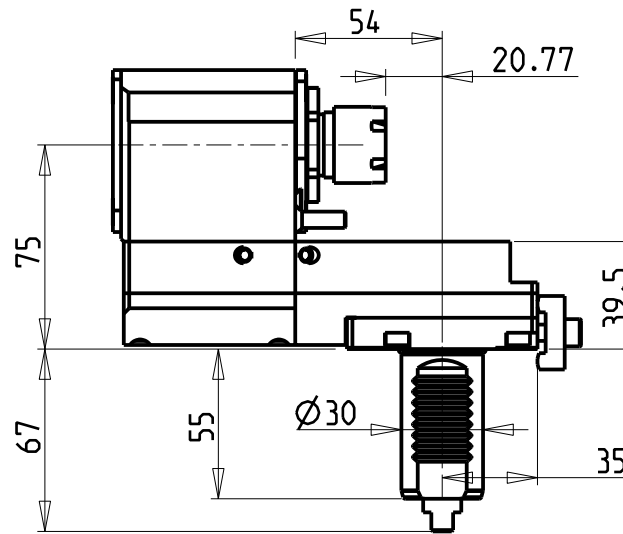
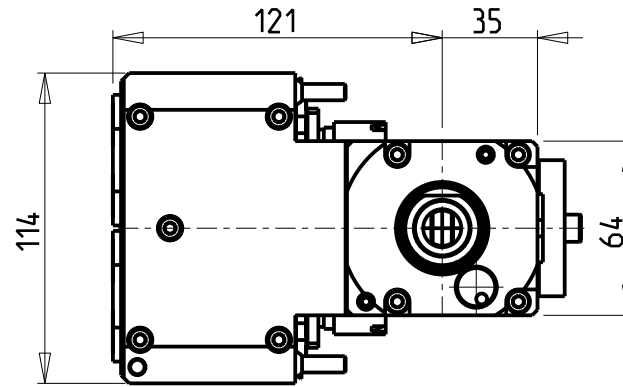

Cod. MT	Mandrino Spindle Spindel	I	RPM	Coppia Max Max Torque Max Drehmoment	Lubr.esterna Ext. coolant Aussenkuehlung	CHIAVI NON INCLUDE Keys not included Schluessel nicht einbegriffen	
HNW 0070120	ER20	1:1	6000	16Nm	X	CHUB38	CHMNER20

HANW HA
 MOD: STL32H/35H/38H (Y3) - STL42H/N/NH (Y3) (VD130)

MODULO MOTORIZZATO RADIALE ARRETRATO 2 USCITE IN Y VD130
 Radial rear-set twin head driven tool in Y VD130
 Radial angetriebenes Werkzeug zurueckversetzt 2 Ausgaenge in Y VD130

Subject to change without notice.

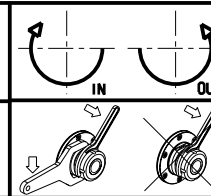

M.T. srl
 Via Casino Albini 480
 Tel. 0541/956034-957884
 Fax 0541/956341
 47842 S. GIOVANNI IN M. (RN)
 e-mail: mtma@mtmarchetti.com
 http://www.mtmarchetti.com



PAGINA HNW 018-1-90