

ATTENZIONE - ATTENTION - ACHTUNG

- VERIFICARE LE MISURE DI INGOMBRO PER POSSIBILE INTERFERENZA SU ALCUNI MODELLI DI MACCHINE
- Please check the overall sizes for possible interferences on some machine models
- Bitte überprüfen sie das ausmass um mögliche interferenzen auf einigen maschinen modellen zu vermeiden

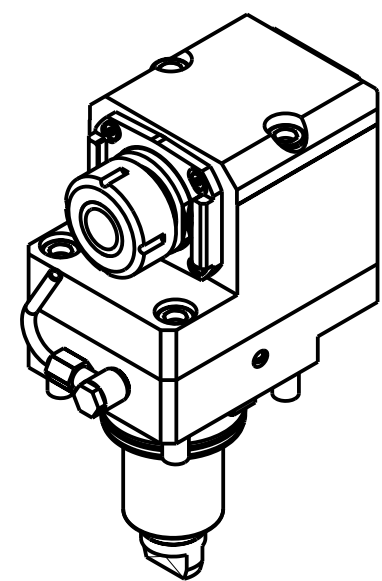
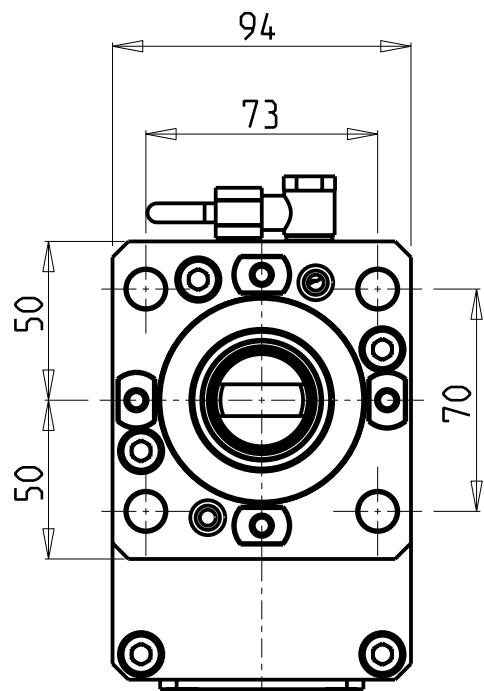
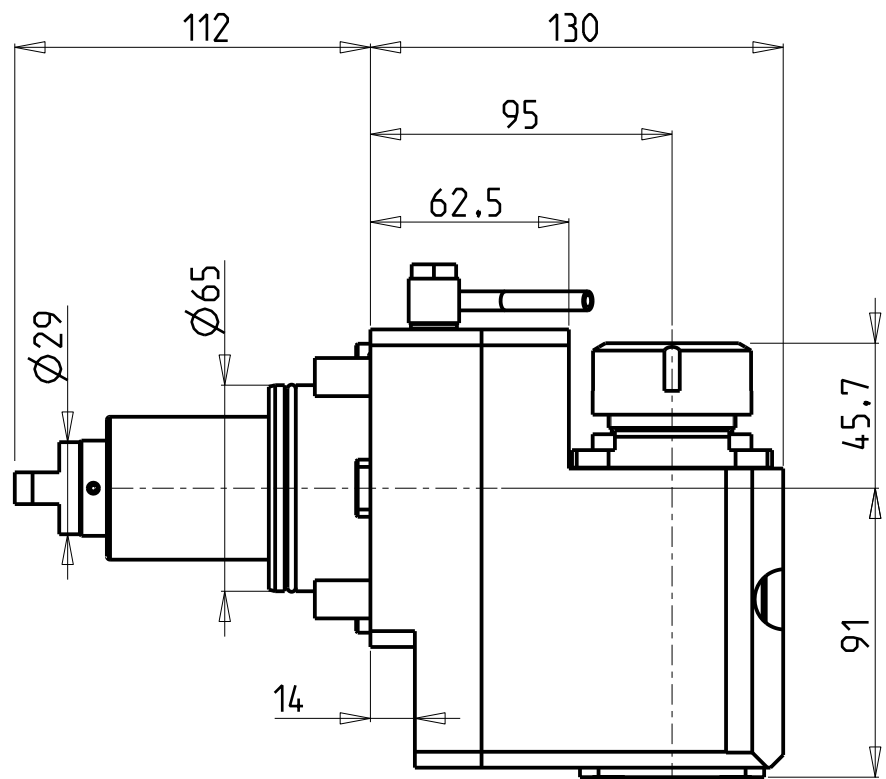

Cod. MT	Mandrino Spindle Spindel	I	RPM	Coppia Max Max Torque Max Drehmoment	Reversibile lato mandrino/contromandrino Reversible sub/main spindle side Umkehrbare Spindel-seite/ Gegenspindel-seite	Lubrificazione est. Ext. coolant Auslenkuehlung	CHIAVI NON INCLUSE Keys not included Schlüssel nicht einbegriffen	
DW 02570132	ER32	1:1	6000	70Nm	X	X	CHSTER32	MNZ0410005 •

- Chiave inclusa
- Key included
- Schlüssel inbegriffen

HW ACHEON
HI-TECH 230 - T2 - CUTEX 240

MODULO MOTORIZZATO ASSIALE ARRETRATO H=95mm
 Axial rear-set driven tool H=95mm
 Axial angetriebenes Werkzeug zurueckversetzt H=95mm

Subject to change without notice.

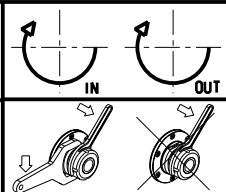

M.T. srl
 Via Casino Albini 480
 Tel. 0541/956034-957884
 Fax 0541/956341
 47842 S. GIOVANNI IN M. (RN)
 e-mail: mtma@mtmarchetti.com
 http://www.mtmarchetti.com



HW C 180-2-25