

ATTENZIONE - ATTENTION - ACHTUNG

- Per lo smontaggio degli utensili utilizzare sempre la chiave di contrasto come indicato nel manuale d'uso.
- For disassembly of the tools use always the contrast key as mentioned in the user instructions.
- Fuer das Abmontieren der Werkzeuge immer den Gegenschlüssel benutzen wie in der Bedienungsanleitung erwäehnt.

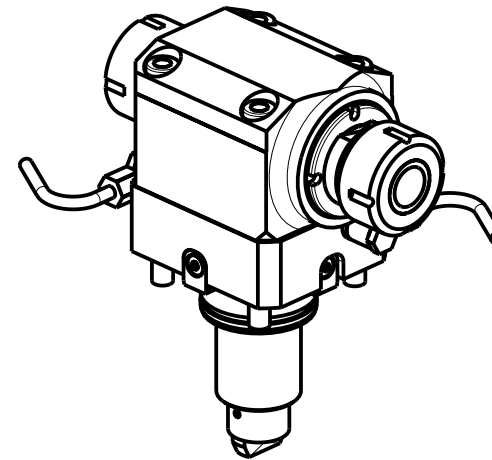
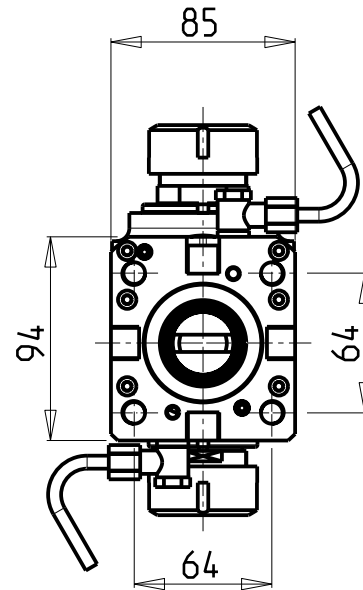
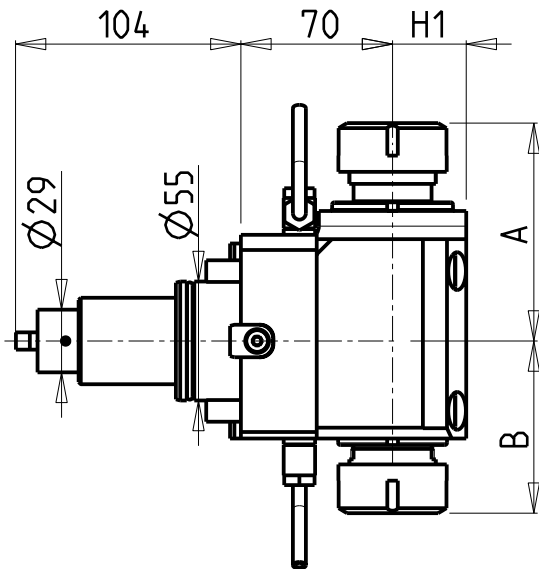

Cod. MT	Mandrino Spindle Spindel	I	RPM	Coppia Max Max Torque Max Drehmoment	Reversibile lato mandrino/contromandrino Reversible sub/main spindle side Umkehrbare Spindelseite/ Gegenspindelseite	Lubrificazione est. Ext. coolant Ausseukuehlung	A	B	H1	CHIAVI NON INCLUSE Keys not included Schlüssel nicht einbegriffen	
DW00080332	ER32+ER32	1:1	6000	50Nm	X	X	100.56	79.46	34	CHSTER32	CHUB36 o 0100000
DW00080325	ER25+ER25	1:1	6000	50Nm	X	X	93.36	73.46	34	CHSTER25	CHUB36+CHUB29

HWACHEON
CUTEX 160/180

MODULO MOTORIZZATO ASSIALE BISPORGENTE H=70mm
Axial opposite face twin driven tool H=70mm
Axial angetriebenes Werkzeug halb vorspringend H=70mm

Subject to change without notice.

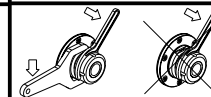

M.T. srl

Via Casino Albini 480
Tel. 0541/956034-957884
Fax 0541/956341
47842 S. GIOVANNI IN M. (RN)
e-mail: mtma@mtmarchetti.com
http://www.mtmarchetti.com



PAGINA HWC240-1-20