

### ATTENZIONE - ATTENTION - ACHTUNG

- VERIFICARE LE MISURE DI INGOMBRO PER POSSIBILE INTERFERENZA SU ALCUNI MODELLI DI MACCHINE
- Please check the overall sizes for possible interferences on some machine models
- Bitte überprüfen sie das ausmass um mögliche interferenzen auf einigen maschinen modellen zu vermeiden

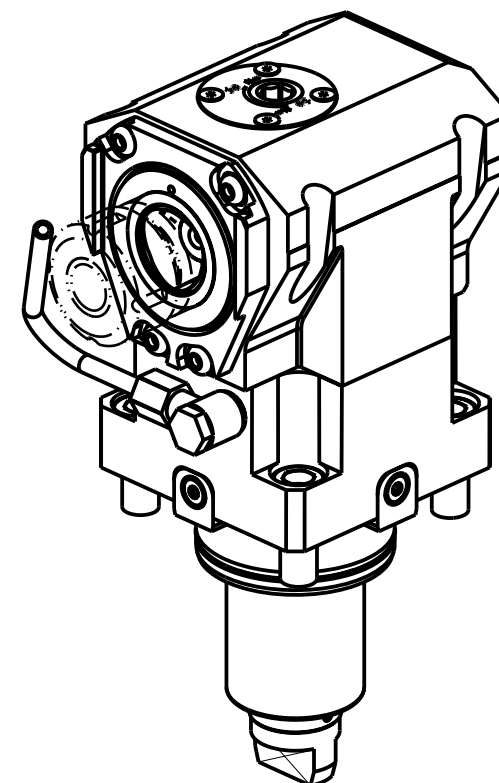
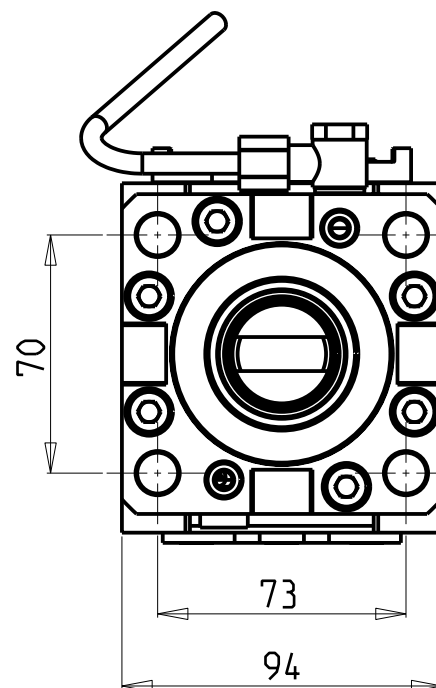
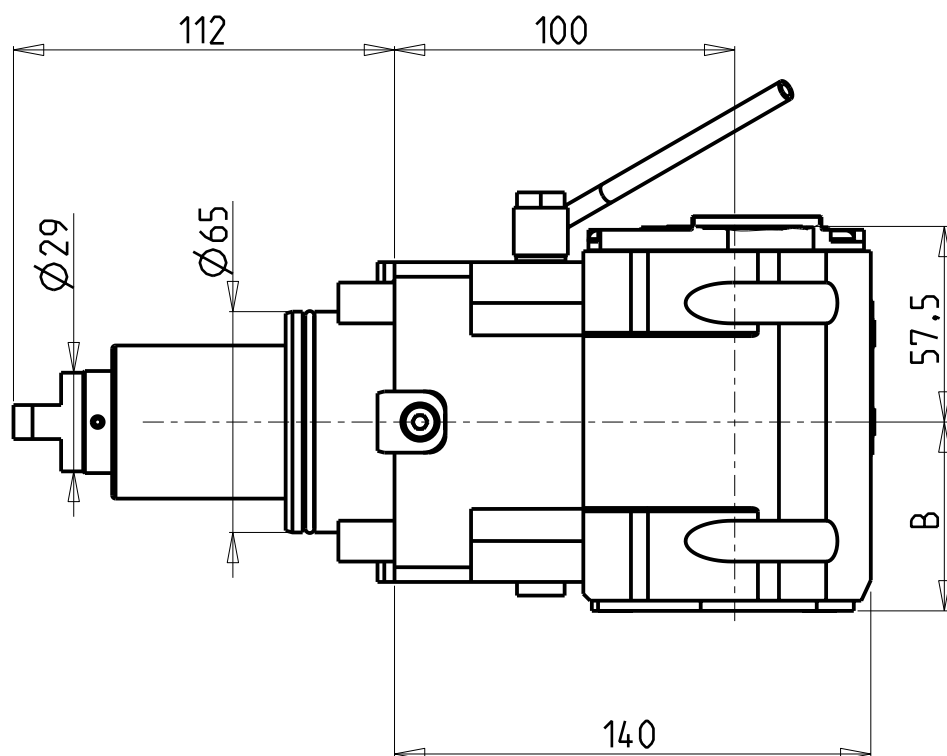

Cod. MT	TAGLIA Size Masse	I	RPM	Coppia Max Max Torque Max Drehmoment	Reversibile lato mandrino/contromandrino Reversible sub/main spindle side Umkehrbare Spindel-seite/ Gegenspindel-seite	Lubr.interna Coolant through Innenkuehlung	Lubr.esterna Ext. coolant Aussenkuehlung	B
DW03130140	C4	1:1	6000	100Nm	X	-	X	55.5
DW03130240	C4	1:1	6000	100Nm	X	P=70bar	X	66.5

#### HYUNDAI-WIA (KIA)

SKT200TTM/TTMS/TTSY - LM2000TTM/TTMS/TTSY - L2000/2600/3000Y/SY - L300M/LM/MS/LMS  
 SKT250TTM/TTMS/TTSY - LM2500TTM/TTMS/TTSY - SKT250M/LM/MS - SKT300M/LM/MS - SKT-V3RM/LM - LV450RM/LM - HD2600/3100 (BMT65)

MODULO MOTORIZZATO ASSIALE MT CAPTO H=100mm

Axial driven tool MT CAPTO H=100mm

Axial angetriebenes Werkzeug MT CAPTO H=100mm

Subject to change without notice.

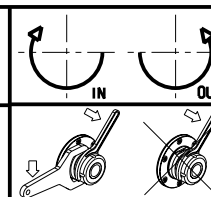

#### M.T. srl

Via Casino Albini 480  
 Tel. 0541/956034-957884  
 Fax 0541/956341  
 47842 S. GIOVANNI IN M. (RN)  
 e-mail: mtma@mtmarchetti.com  
 http://www.mtmarchetti.com



KIA150-C-43