

## CUSCINETTI MAGGIORATI PER LAVORAZIONI PESANTI

Reinforced bearings for  
heavy machining

Vergroesserte Lager fuer  
schwerere Bearbeitungen

### ATTENZIONE - ATTENTION - ACHTUNG

- VERIFICARE LE MISURE DI INGOMBRO PER POSSIBILE INTERFERENZA SU ALCUNI MODELLI DI MACCHINE
- Please check the overall sizes for possible interferences on some machine models
- Bitte überprüfen sie das ausmass um mögliche interferenzen auf einigen maschinen modellen zu vermeiden

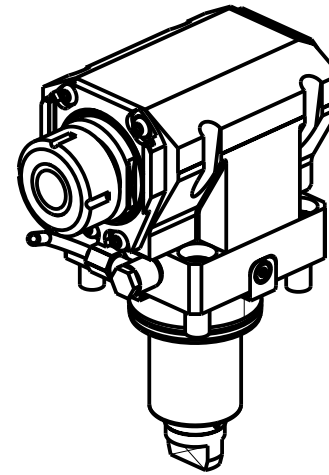
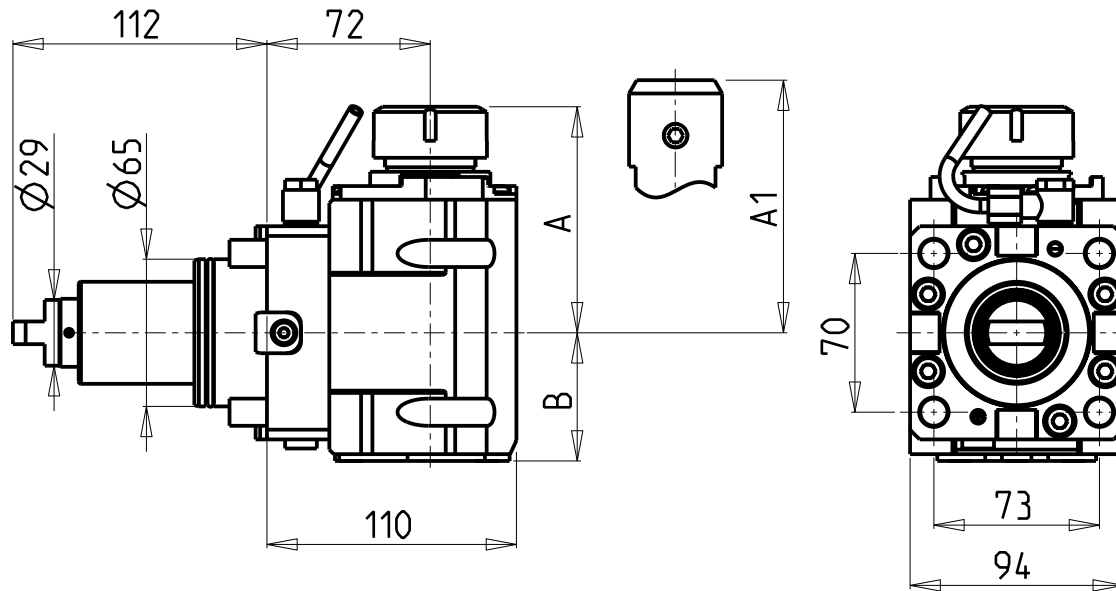

• Chiave inclusa

• Key included

• Schlüssel inbegriffen

Cod. MT	Mandrino Spindle Spindel	I	RPM	Coppia Max Max Torque Max Drehmoment	Reversibile lato mandrino/contromandrino Reversible sub/main spindle side Umkehrbare Spindel-seite/ Gegenspindel-seite	Lubr.interna Coolant through Innenkuehlung	Lubr.esterna Ext. coolant Aussenkuehlung	A	A1	B	CHIAVI NON INCLUDE Keys not included Schlüssel nicht einbegriffen	
DW02470132	ER32	1:1	6000	110Nm	X	-	X	99.7	-	56.5	CHSTER32	OKU0650004
DW02470232	ER32	1:1	6000	110Nm	X	P=70bar	X	99.7	-	67.5	CHSTER32	OKU0650004
DW02470725	WELDON25	1:1	6000	110Nm	X	-	X	-	106	56.5	-	-
DW02470825	WELDON25	1:1	6000	110Nm	X	P=70bar	X	-	106	67.5	-	-

### HYUNDAI-WIA (KIA)

SKT200TTM/TTMS/TTSY - LM2000TTM/TTMS/TTSY - L2000/2100/2600/3000Y/SY - L300M/LM/MS/LMS  
SKT250TTM/TTMS/TTSY - LM2500TTM/TTMS/TTSY - SKT250M/LM/MS - SKT300M/LM/MS - SKT-V3RM/LM - LV450RM/LM - HD2600/3100 (BMT65)

MODULO MOTORIZZATO ASSIALE MAGGIORATO H=72mm

Axial reinforced driven tool H=72mm

Axial angetriebenes Werkzeug vergroessert H=72mm

Subject to change without notice.

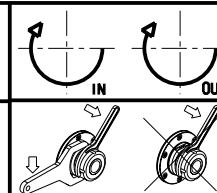

### M.T. srl

Via Casino Albini 480  
Tel. 0541/956034-957884  
Fax 0541/956341  
47842 S. GIOVANNI IN M. (RN)  
e-mail: mtma@mtmarchetti.com  
http://www.mtmarchetti.com



KIA170-3-10