

**CUSCINETTI MAGGIORATI  
PER LAVORAZIONI PESANTI**

Reinforced bearings for heavy machining  
Vergroesserte Lager fuer schwerere Bearbeitungen

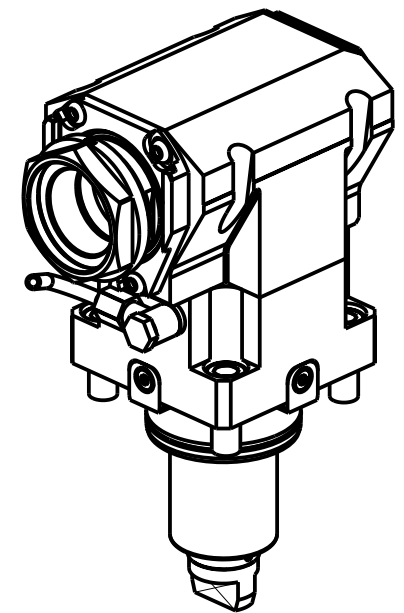

- Chiave inclusa
- Key included
- Schluessel inbegriffen

PER PORTAUTENSILI MODULARI MTSK-50 VEDI PAG. TBL300-1-50  
FOR MTSK-50 QUICK CHANGE TOOLHOLDERS CLAMPINGS SEE PAGE TBL300-1-50  
FUER MTSK-50 MODULARE WERKZEUGAUFNAHMEN SIEHE SEITE TBL300-1-50

Cod. MT	Mandrino Spindle Spindel	I	RPM	Coppia Max Max Torque Max Drehmoment	Reversibile lato mandrino/contromandrino Reversible sub/main spindle side Umkehrbare Spindel-seite/ Gegenspindel-seite	Luobr.interna Coolant through Innenkuehlung	Luobr.esterna Ext. coolant Aussenkuehlung	B	CHIAVI NON INCLUDE Keys not included Schluessel nicht einbegriffen	
DW02200150	MTSK-50	1:1	6000	110Nm	X	-	X	56.5	CHUB55	OKU0650004 *
DW02200250	MTSK-50	1:1	6000	110Nm	X	P=70bar	X	67.5	CHUB55	OKU0650004 *

**HYUNDAI-WIA (KIA)**  
SKT200TTM/TTMS/TTSY - LM2000TTM/TTMS/TTSY - L2000/2600/3000Y/SY - L300M/LM/MS/LMS  
SKT250TTM/TTMS/TTSY - LM2500TTM/TTMS/TTSY - SKT250M/LM/MS - SKT300M/LM/MS - SKT-V3RM/LM - LV450RM/LM - HD2600/3100 (BMT65)

**MODULO MOTORIZZATO ASSIALE MAGGIORATO MTSK H=100mm**  
Axial MTSK reinforced driven tool H=100mm  
Axial MTSK angetriebenes Werkzeug vergroessert H=100mm

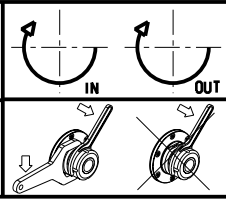

**M.T. srl**  
Via Casino Albini 480  
Tel. 0541/956034-957884  
Fax 0541/956341  
47842 S. GIOVANNI IN M. (RN)  
e-mail: mtma@mtmarchetti.com  
http://www.mtmarchetti.com



**KIA170-3-30-K**

Subject to change without notice.