

ATTENZIONE - ATTENTION - ACHTUNG

- VERIFICARE LE MISURE DI INGOMBRO PER POSSIBILE INTERFERENZA SU ALCUNI MODELLI DI MACCHINE
- Please check the overall sizes for possible interferences on some machine models
- Bitte überprüfen sie das ausmass um mögliche interferenzen auf einigen maschinen modellen zu vermeiden

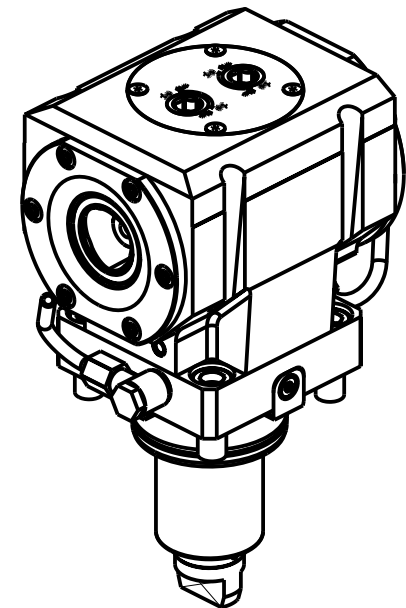

Cod. MT	TAGLIA Size Masse	I	RPM	Coppia Max Max Torque Max Drehmoment	Reversibile lato mandrino/contromandrino Reversible sub/main spindle side Umkehrbare Spindelseite/ Gegenspindelseite	Lubr.esterna Ext. coolant Aussenkuehlung
DW03140240	C4+C4	1:1	6000	100Nm	X	X

HYUNDAI-WIA (KIA)

SKT200TTM/TTMS/TTSY - LM2000TTM/TTMS/TTSY - SKT250TTM/TTMS/TTSY - LM2500TTM/TTMS/TTSY
 SKT250M/LM/MS - SKT300M/LM/MS - L300M/LM/MS/LMS - L2000/2600/3000Y/SY - HD2600/3100 (BMT65)

MODULO MOTORIZZATO ASSIALE BISPORGENTE MT CAPTO H=85mm

Axial opposite face twin driven tool MT CAPTO H=85mm

Axial angetriebenes Werkzeug halb vorspringend mit MT CAPTO H=85mm

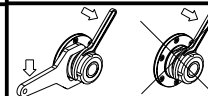

M.T. srl

Via Casino Albini 480
 Tel. 0541/956034-957884
 Fax 0541/956341
 47842 S. GIOVANNI IN M. (RN)
 e-mail: mtma@tmarchetti.com
 http://www.tmmarchetti.com



KIA240-C-41

Subject to change without notice.

03/2024