

PER BOCCOLE DI RIDUZIONE VEDI PAG. TBL150-1-00  
 FOR REDUCING BUSHINGS SEE PAGE TBL150-1-00  
 FÜR REDUZIERBUCHSE SIEHE SEITE TBL150-1-00

KIT ADDUZIONE INTERNA (OPZIONALE)  
 KIT FOR INTERNAL COOLANT (OPTIONAL)  
 KIT FÜR INTERNE KUEHLMITTELZUFUHR (OPTIONAL)  
 Ø40 cod. KIT1000003  
 Ø1 1/2" cod. KIT1000004

**ATTENZIONE - ATTENTION - ACHTUNG**

FUORI VOLTEGGIO!  
 OUT OF MAXIMUM SWING!  
 WERKZEUG AUSSER INTERFERENZ!

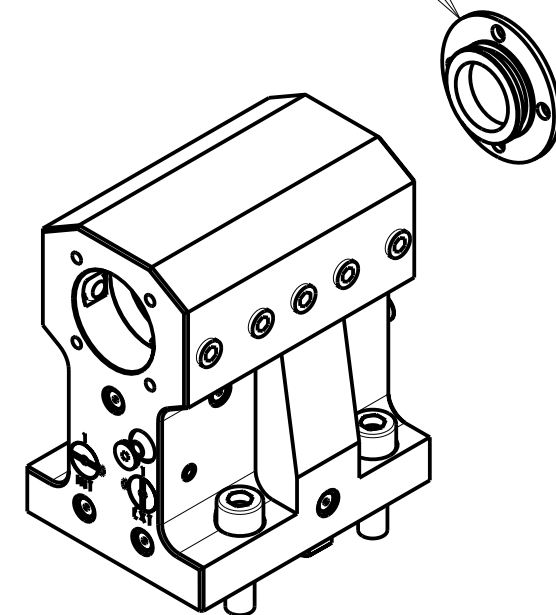

Cod. MT	N°Utensili N°Tools N°Werkzeuge	Reversibile lato mandrino/contromandrino Reversible sub/main spindle side Umkehrbare Spindel-seite/ Gegenspindel-seite	Lubrificazione int. opzionale Coolant through optional Innenkuehlung Optional	Lubrificazione est. Ext. coolant Aussenkuehlung	Misure Dimensions Masse	D
DW00394000	1	X	X	X	mm	40
DW00393810	1	X	X	X	Inch	1 1/2"

HYUNDAI-WIA (KIA)

MOD: SKT160TTMS/TTSY - LM1600TTMS/TTSY - SKT180TTMS/TTSY - LM1800TTMS/TTSY - L160/230LMSA - SE2600M  
 HD2200-2600M/Y/SY (BMT55)

PORTAUTENSILE ASSIALE PER BARENO Ø40mm / Ø1 1/2" H=100mm

Axial single boring bar holder Ø40mm / Ø1 1/2" H=100mm

Axial Bohrhälter Ø40mm / Ø1 1/2" H=100mm

**M.T. srl**

Via Casino Albini 480  
 Tel. 0541/956034-957884  
 Fax 0541/956341  
 47842 S. GIOVANNI IN M. (RN)  
 e-mail: mtma@mtmarchetti.com  
 http://www.mtmarchetti.com



KIA640-2-10

Subject to change without notice.

03/2024