

ATTENZIONE - ATTENTION - ACHTUNG

- Per lo smontaggio degli utensili utilizzare sempre la chiave di contrasto come indicato nel manuale d'uso.
- For disassembly of the tools use always the contrast key as mentioned in the user instructions.
- Fuer das Abmontieren der Werkzeuge immer den Gegenschlüssel benutzen wie in der Bedienungsanleitung erwäehnt.

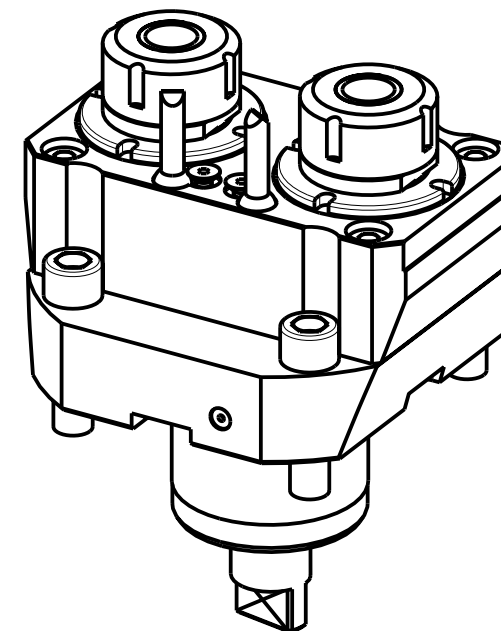
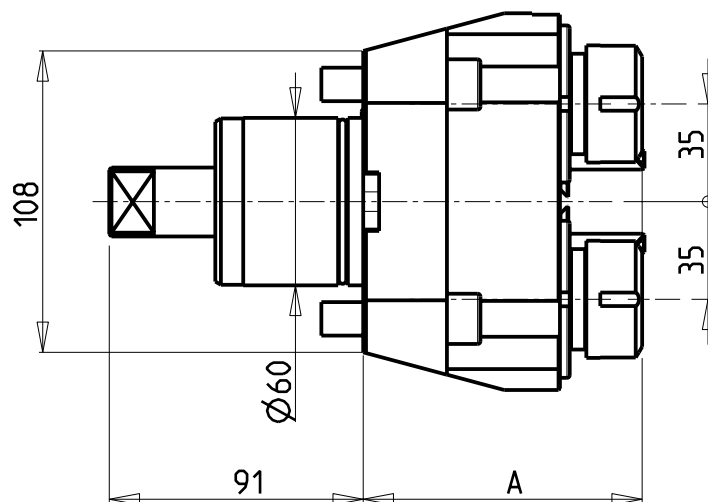
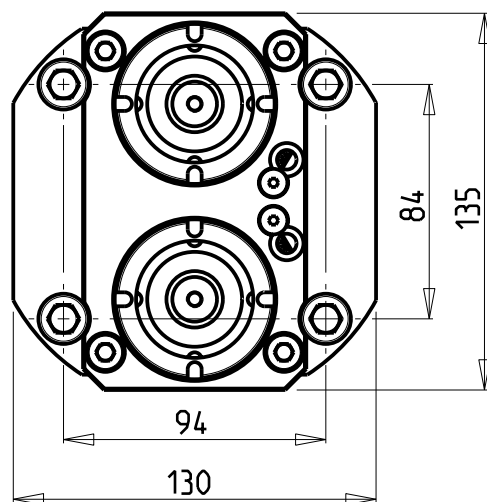

- Chiave inclusa
- Key included
- Schlüssel inbegriffen

Cod. MT	Mandrino Spindle Spindel	I	RPM	Coppia Max Max Torque Max Drehmoment	Lubrificazione est. Ext. coolant Ausseukuehlung	A	CHIAVI NON INCLUSE Keys not included Schluesssel nicht einbegriffen		
MNL1070225	ER25	1:1	12000	40Nm	X	99.96	CHUB36	CHSTER25	-
MNL1070325	ERA25	1:1	12000	40Nm	X	88.5	CHUB38	CHUB27	CHTAER25ZC *

DMG-MORI

NL1500/2000/2500/3000 12 ST. - NLX1500/2000/2500/3000 12 ST. - NLX2500 2ND GEN. 12ST. - NLX4000 - NZL2000/2500 NZX2500 (BMT60) - NT4200/4250/4300/5400 - NTX2000/2500/3000 2ND GEN. 10ST. - CTX2500 (BMT60)

MODULO MOTORIZZATO RADIALE 2 USCITE IN Y 12000 RPM

Radial single side twin head driven tool in Y 12000 rpm

Radial angetriebenes Werkzeug 2 Ausgaenge in Y 12000 rpm

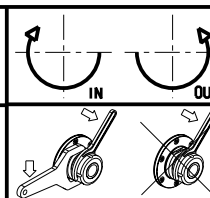

M.T. srl

Via Casino Albini 480
Tel. 0541/956034-957884
Fax 0541/956341
47842 S. GIOVANNI IN M. (RN)
e-mail: mtma@mtmarchetti.com
http://www.mtmarchetti.com



MNL080-1-01

Subject to change without notice.

10/2024