

**ATTENZIONE - ATTENTION - ACHTUNG**

- Per lo smontaggio degli utensili utilizzare sempre la chiave di contrasto come indicato nel manuale d'uso.
- For disassembly of the tools use always the contrast key as mentioned in the user instructions.
- Fuer das Abmontieren der Werkzeuge immer den Gegenschlüssel benutzen wie in der Bedienungsanleitung erwäehnt.

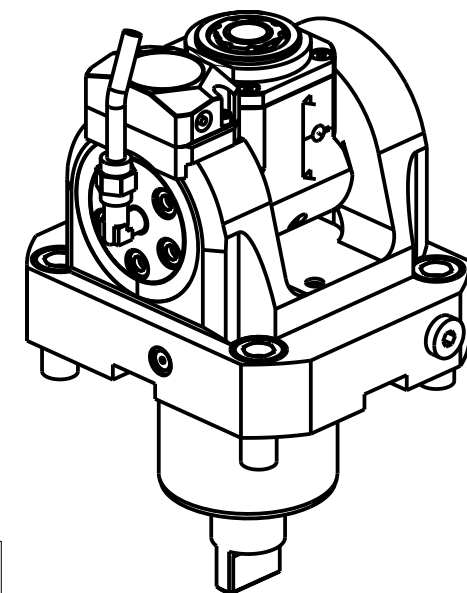

Cod. MT	Mandrino Spindle Spindel	i	RPM	Coppia Max Max Torque Max Drehmoment	Lubrificazione int. Coolant through Innenkuehlung	Lubrificazione est. Ext. coolant Ausenkuehlung	CHIAVI INCLUSE Keys included Schluessel inbegriffen			
							CHUB22	CHUB36	CHTAER20ZC	CHESL10
MNL0645120	ERA20	1:1	6000	30Nm	-	X	CHUB22	CHUB36	CHTAER20ZC	CHESL10
MNL0645220	ERA20	1:1	6000	30Nm	P=70bar	X	CHUB22	CHUB36	CHTAER20ZC	CHESL10

**DMG-MORI**  
 NL1500/2000/2500/3000 12 ST. - NLX1500/2000/2500/3000 12 ST. - NLX2500 2ND GEN. 12ST. - NLX4000 - NZL2000/2500 NZX2500 (BMT60) - NT4200/4250/4300/5400 - NTX2000/2500/3000 2ND GEN. 10ST. - CTX2500 (BMT60)

**MODULO MOTORIZZATO ORIENTABILE +/-90° CON NONIO DIGITALE**  
 +/-90° adjustable angle driven tool with digital display  
 Angetriebenes Werkzeug schwenkbar +/-90° mit digital display

Subject to change without notice.

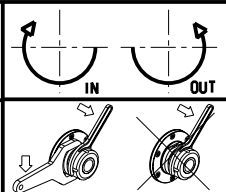

**M.T. srl**  
 Via Casino Albini 480  
 Tel. 0541/956034-957884  
 Fax 0541/956341  
 47842 S. GIOVANNI IN M. (RN)  
 e-mail: mtma@mtmarchetti.com  
 http://www.mtmarchetti.com



MNL335-1-01