

-LA FUNZIONE DI POLIGONATURA/DENTATURA  
DEVE ESSERE INSTALLATA SULLA MACCHINA  
-POLYGON CUTTING/GEAR HOBBING FUNCTION  
MUST BE INSTALLED ON THE MACHINE  
-DIE FUNKTION FÜR POLYGON-BZW.VERZÄHNUNGSFRÄSEN  
MUSS AUF DER MASCHINE FREIGESCHALTET WERDEN

ATTENZIONE - ATTENTION - ACHTUNG

- VERIFICARE LE MISURE DI INGOMBRO PER POSSIBILE INTERFERENZA SU ALCUNI MODELLI DI MACCHINE
- Please check the overall sizes for possible interferences on some machine models
- Bitte überprüfen sie das ausmass um mögliche interferenzen auf einigen maschinen modellen zu vermeiden

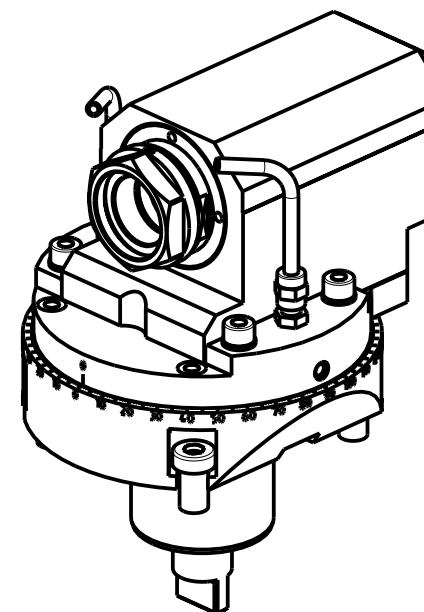
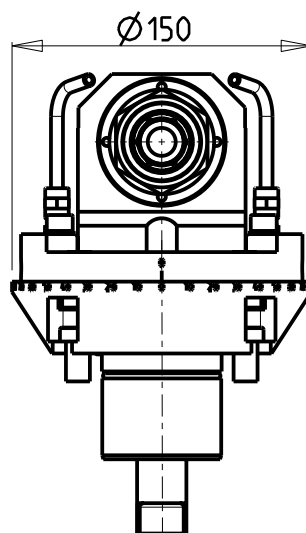
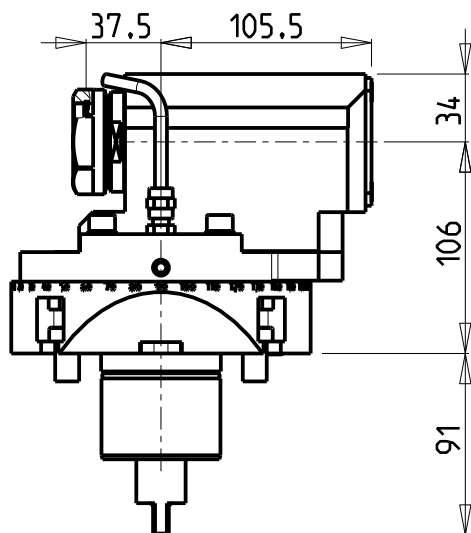

-SOLO PER MACCHINE CON ASSE Y  
-ONLY FOR MACHINES WITH Y AXIS  
-NUR FÜR MASCHINEN MIT Y-ACHSE

PER PORTAUTENSILI MODULARI MTSK-40 VEDI PAG. TBL300-1-40  
FOR MTSK-40 QUICK CHANGE TOOLHOLDERS CLAMPINGS SEE PAGE TBL300-1-40  
FÜR MTSK-40 MODULARE WERKZEUGAUFNAHMEN SIEHE SEITE TBL300-1-40

Cod. MT	Mandrino Spindle Spindel	I	RPM	Coppia Max Max Torque Max Drehmoment	Lubr.esterna Ext. coolant Aussenkuehlung	CHIAVI INCLUDE Keys included Schlüssel einbegriffen
MNL0870100	MTSK-40	1:1	6000	50Nm	X	n°2 CHUB46

DMG-MORI

NL1500/2000/2500/3000 12 STAZIONI - NLX1500/2000/2500/3000 12 STAZIONI - NLX4000 - NZL2000/2500 - NZX2500 (BMT60)  
NTX2000/2500/3000 2ND GEN. 10ST. - CTX2500 (BMT60)

MODULO MOTORIZZATO ASSIALE MTSK PER POWER SKIVING H=106mm

Axial MTSK driven tool for Power Skiving H=106mm

Axial MTSK angetriebenes Werkzeug fuer Power Skiving H=106mm

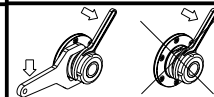

M.T. srl

Via Casino Albini 480  
Tel. 0541/956034-957884  
Fax 0541/956341

47842 S. GIOVANNI IN M. (RN)  
e-mail: mtma@mtmarchetti.com  
http://www.mtmarchetti.com



MNL350-1-00-K

Subject to change without notice.

03/2024