

ATTENZIONE - ATTENTION - ACHTUNG

- VERIFICARE LE MISURE DI INGOMBRO PER POSSIBILE INTERFERENZA SU ALCUNI MODELLI DI MACCHINE
- Please check the overall sizes for possible interferences on some machine models
- Bitte überprüfen sie das ausmass um mögliche interferenzen auf einigen maschinen modellen zu vermeiden

ATTENZIONE - ATTENTION - ACHTUNG

- Per lo smontaggio degli utensili utilizzare sempre la chiave di contrasto come indicato nel manuale d'uso.
- For disassembly of the tools use always the contrast key as mentioned in the user instructions.
- Fuer das Abmontieren der Werkzeuge immer den Gegenschlüssel benutzen wie in der Bedienungsanleitung erwaeht.

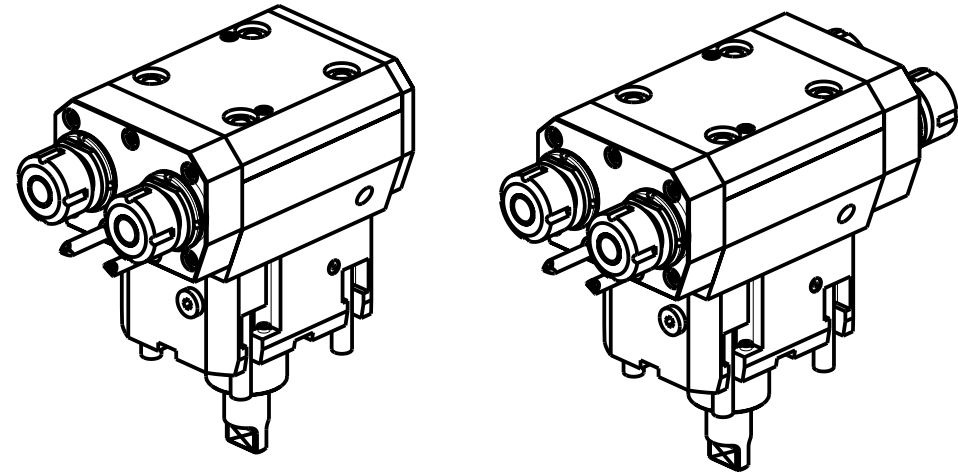
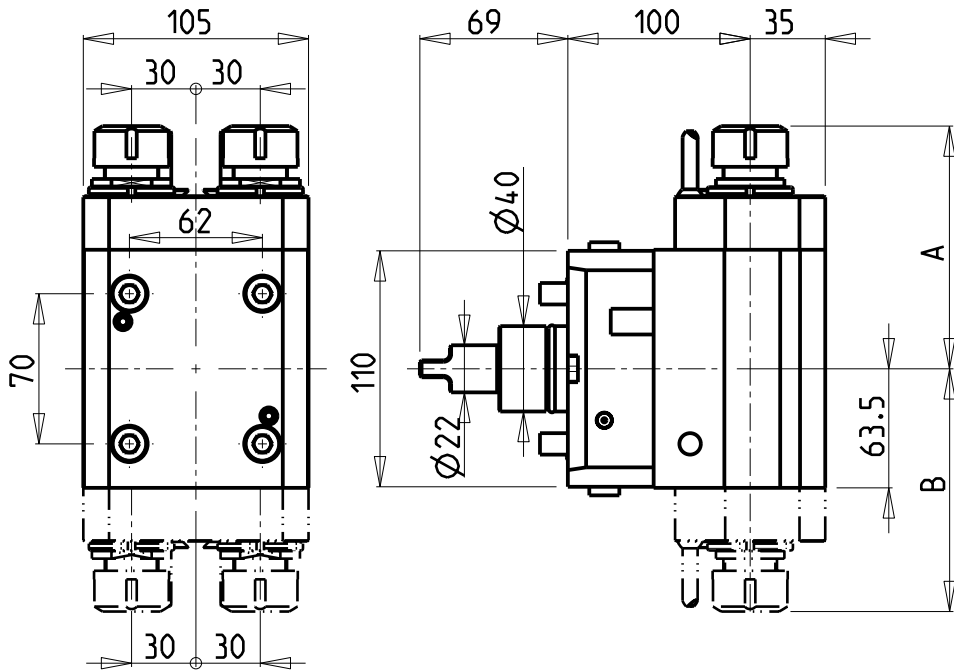

Cod. MT	Mandrino Spindle Spindel	I	RPM	Coppia Max Max Torque Max Drehmoment	N°Utensili N°Tools N°Werkzeuge	Reversibile lato mandrino/contromandrino Reversible sub/main spindle side Umkehrbare Spindel-seite/ Gegenspindel-seite	Lubr.esterna Ext. coolant Aussenkuehlung	A	B	CHIAVI NON INCLUSE Keys not included Schluessel nicht einbegriffen	
MNZ0611316	ERA16	1:1	12000	40Nm	2	X	X	96.63	-	CHUB32	CHUB19_SP3
MNZ0611320	ER20	1:1	12000	40Nm	2	X	X	113.16	-	CHUB32	CHSTER20
MNZ0611416	ERA16+ERA16	1:1	12000	40Nm	2+2	X	X	96.63	96.63	CHUB32	CHUB19_SP3
MNZ0611420	ER20+ER20	1:1	12000	40Nm	2+2	X	X	113.16	113.16	CHUB32	CHSTER20

DMG-MORI

NZ1500/2000 - NZX1500/2000 - NL1500/2000/2500 20 STAZ. - NLX1500/2000/2500 20 STAZ. - NTX1000/2000 ALC/ALX1500/2000/2500 (BMT40)

MODULO MOTORIZZATO ASSIALE 2/4 USCITE IN Y 12000 RPM H=100mm

Axial multiple 2/4 outlet driven tool in Y 12000 rpm H=100mm

Axial angetriebenes Mehrspindel-Werkzeug 2/4 Ausgaenge in Y 12000 rpm H=100mm

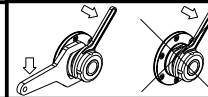

M.T. srl

Via Casino Albini 480
Tel. 0541/956034-957884
Fax 0541/956341
47842 S. GIOVANNI IN M. (RN)
e-mail: mtma@mtmarchetti.com
http://www.mtmarchetti.com



MNZ268-1-11

Subject to change without notice.