

ATTENZIONE - ATTENTION - ACHTUNG

- VERIFICARE LE MISURE DI INGOMBRO PER POSSIBILE INTERFERENZA SU ALCUNI MODELLI DI MACCHINE
- Please check the overall sizes for possible interferences on some machine models
- Bitte überprüfen sie das ausmass um mögliche interferenzen auf einigen maschinen modellen zu vermeiden

ATTENZIONE - ATTENTION - ACHTUNG

- Per lo smontaggio degli utensili utilizzare sempre la chiave di contrasto come indicato nel manuale d'uso.
- For disassembly of the tools use always the contrast key as mentioned in the user instructions.
- Fuer das Abmontieren der Werkzeuge immer den Gegenschlüssel benutzen wie in der Bedienungsanleitung erwaeht.

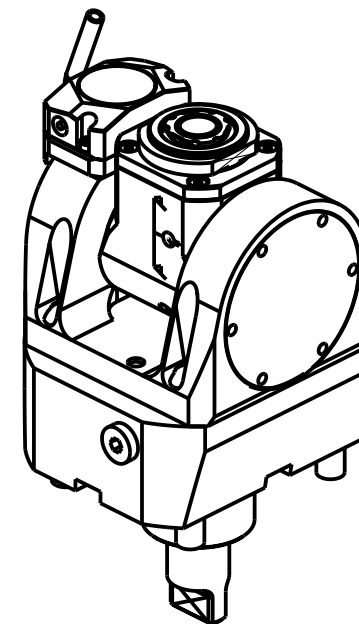
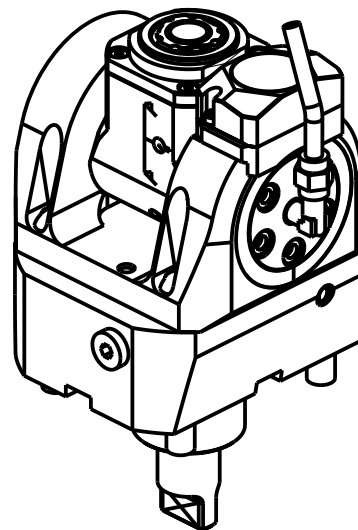

Cod. MT	Mandrino Spindle Spindel	I	RPM	Coppia Max Max Torque Max Drehmoment	Lubrificazione int. Coolant through Innenkuehlung	Lubrificazione est. Ext. coolant Aussenkuehlung	CHIAVI INCLUSE Keys included Schlüssel inbegriffen			
MNZ0586120	ER A 20	1:1	12000	30Nm	-	X	CHUB36	CHUB22	CHESL08	CHTAER20ZC
MNZ0586220	ER A 20	1:1	12000	30Nm	P=70bar	X	CHUB36	CHUB22	CHESL08	CHTAER20ZC

DMG-MORI

NZ1500/2000 - NZX1500/2000 - NZX2500 (BMT40) - NL1500/2000/2500 20 STAZ. - NLX1500/2000/2500 20 STAZ. - NTX500 (BMT40)
 NTX1000/2000 - NTX1000/2000/2500/3000 2ND GEN. - NRX2000 - ALC/ALX1500/2000/2500 (BMT40) - NZ DUE/TRE/QUATTRO (BMT40)

MODULO MOTORIZZATO ORIENTABILE +/-90° 12000 RPM CON NONIO DIGITALE H=77mm

+/-90° adjustable angle driven tool 12000 rpm with digital display H=77mm

Angetriebenes Werkzeug schwenkbar +/-90° 12000 rpm mit digital display H=77mm

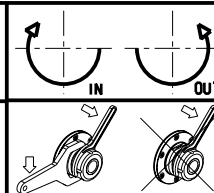

M.T. srl

Via Casino Albini 480
 Tel. 0541/956034-957884
 Fax 0541/956341

47842 S. GIOVANNI IN M. (RN)
 e-mail: mtma@mtmarchetti.com
 http://www.mtmarchetti.com



MNZ335-1-13

Subject to change without notice.

09/2024