

ATTENZIONE - ATTENTION - ACHTUNG

- Per lo smontaggio degli utensili utilizzare sempre la chiave di contrasto come indicato nel manuale d'uso.
- For disassembly of the tools use always the contrast key as mentioned in the user instructions.
- Fuer das Abmontieren der Werkzeuge immer den Gegenschlüssel benutzen wie in der Bedienungsanleitung erwaeht.

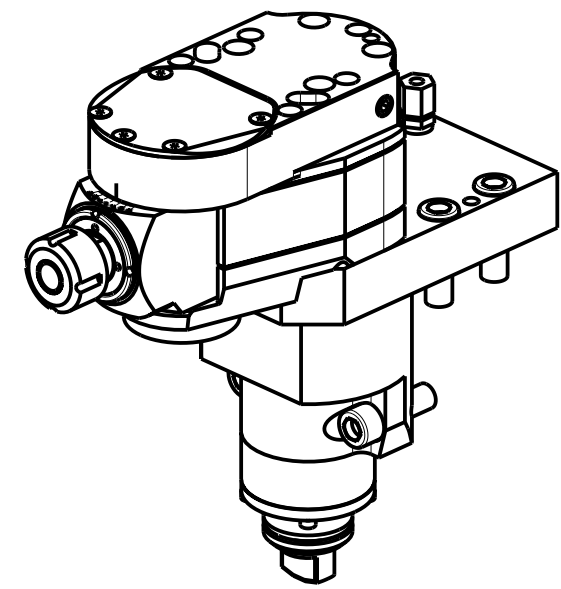

Cod. MT	Mandrino Spindle Spindel	I	RPM	Coppia Max Max Torque Max Drehmoment	Lubrificazione est. Ext. coolant Aussenkuehlung	A	A1	D	L	CHIAVI INCLUSE Keys included Schluessel inbegriffen
M0110020	ER20	1:1	6000	40Nm	X	84.16				MNL0210007 o CHUB36 CHSTER20
M0110025	ER25	1:1	6000	40Nm	X	85.66				MNL0210007 o CHUB36 CHSTER25
M0111617	Ø16x17	1:1	6000	40Nm	X	-	65	16	17	MNL0210007 o CHUB36 CH_VTCROCE_M08

DMG-MORI
MOD: SL300/303

MODULO MOTORIZZATO INCLINEVOLE ±15° IN Y
±15° Y axis adjustable angle driven tool
Angetriebenes Werkzeug kippbar ±15° in Y

Subject to change without notice.

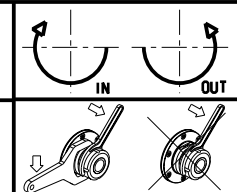

M.T. srl
Via Casino Albini 480
Tel. 0541/956034-957884
Fax 0541/956341
47842 S. GIOVANNI IN M. (RN)
e-mail: mtma@mtmarchetti.com
http://www.mtmarchetti.com



MSL358-3-00