

CUSCINETTI MAGGIORATI PER LAVORAZIONI PESANTI

Reinforced bearings for
heavy machining

Vergroesserte Lager fuer
schwerere Bearbeitungen

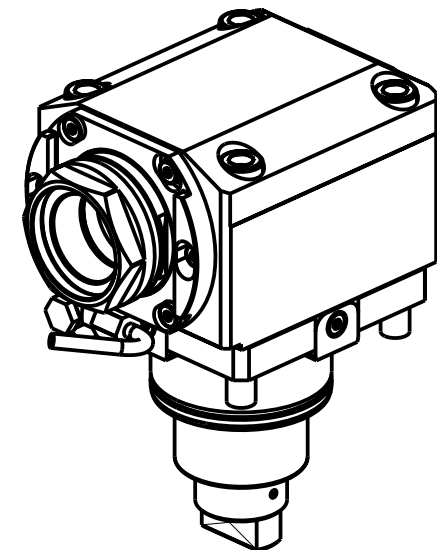

PER PORTAUTENSILI MODULARI MTSK-50 VEDI PAG. TBL300-1-50
FOR MTSK-50 QUICK CHANGE TOOLHOLDERS CLAMPINGS SEE PAGE TBL300-1-50
FUER MTSK-50 MODULARE WERKZEUGAUFNAHMEN SIEHE SEITE TBL300-1-50

Cod. MT	Mandrino Spindle Spindel	I (n1:n2)	RPM max n2	Coppia Max Max Torque Max Drehmoment M2 [Nm]	Reversibile lato mandrino/contromandrino Reversible sub/main spindle side Umkehrbare Spindel-seite/ Gegenspindel-seite	Lubrificazione int. Coolant through Innenkuehlung Pmax [bar]	Lubr.esterna Ext. coolant Aussenkuehlung	B	CHIAVI NON INCLUDE Keys not included Schluessel nicht einbegriffen	
DW 0214 0150	MTSK-50	1:1	6000	140	X	-	X	64	CHUB55	OKU04 30007 •
DW 0214 0250	MTSK-50	1:1	6000	140	X	70	X	76.5	CHUB55	OKU04 30007 •

- Chiave inclusa
- Key included
- Schluessel inbegriffen

MT EVO (MTRent)

MOD: T36FMC 12ST.

MODULO MOTORIZZATO ASSIALE MAGGIORATO MTSK H=60mm

Axial MTSK reinforced driven tool H=60mm

Axial MTSK angetriebenes Werkzeug vergroessert H=60mm

Subject to change without notice.

M.T. srl

Via Casino Albini 480
Tel. 0541/956034-957884
Fax 0541/956341
47842 S. GIOVANNI IN M. (RN)
e-mail: mtma@mtmarchetti.com
http://www.mtmarchetti.com



MTR170-3-10-K