

-LA FUNZIONE DI POLIGONATURA/DENTATURA  
 DEVE ESSERE INSTALLATA SULLA MACCHINA  
 -POLYGON CUTTING/GEAR HOBBING FUNCTION  
 MUST BE INSTALLED ON THE MACHINE  
 -DIE FUNKTION FÜR POLYGON-BZW. VERZÄHNUNGSFRÄSEN  
 MUSS AUF DER MASCHINE FREIGESCHALTET WERDEN

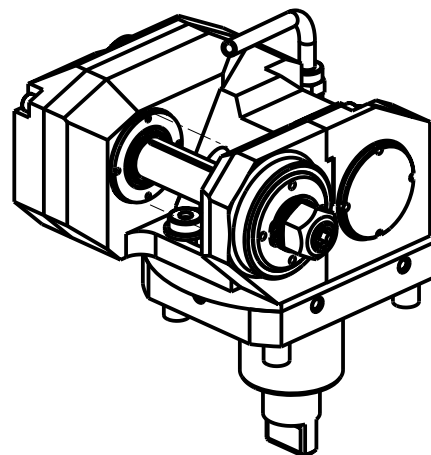

ATTENZIONE - ATTENTION - ACHTUNG

- VERIFICARE LE MISURE DI INGOMBRO PER POSSIBILE INTERFERENZA
- Please check the overall sizes for possible interferences
- Bitte überprüfen sie das Ausmass um mögliche Interferenzen zu vermeiden

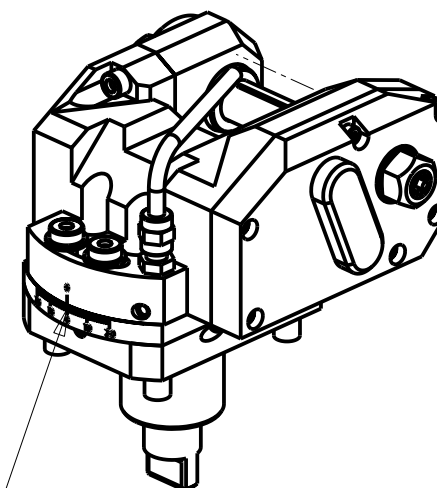

INCLINAZIONE  
 REGOLABILE  $\pm 20^\circ$

Cod. MT	I	RPM max	Coppia Max Max Torque Max Drehmoment	Lubrificazione est. Ext. coolant Aussenkuehlung	D	CHIAVI INCLUSE Keys included Schlüssel inbegriffen				
MUR0211116	1:1	6000	30Nm	X	16	CHUB19	CHESL06	CHESL05	-	-
MUR0211113	1:1	6000	30Nm	X	13	CHUB19	CHESL06	CHESL05	-	-
MUR0211110	1:1	6000	30Nm	X	10	CHUB19	CHESL06	CHESL05	-	CHUB17
MUR0211108	1:1	6000	30Nm	X	8	CHUB19	CHESL06	CHESL05	CHESL04	CHUB13
MUR0211155	1:1	6000	30Nm	X	1/2"	CHUB19	CHESL06	CHESL05	-	-
MUR0212116	2:1	3000	50Nm	X	16	CHUB19	CHESL06	CHESL05	-	-
MUR0212113	2:1	3000	50Nm	X	13	CHUB19	CHESL06	CHESL05	-	-
MUR0212110	2:1	3000	50Nm	X	10	CHUB19	CHESL06	CHESL05	-	CHUB17
MUR0212108	2:1	3000	50Nm	X	8	CHUB19	CHESL06	CHESL05	CHESL04	CHUB13
MUR0212155	2:1	3000	50Nm	X	1/2"	CHUB19	CHESL06	CHESL05	-	-

MURATEC

MOD: MT12 - MT200

MODULO MOTORIZZATO PORTACREATORE

Driven gear hobber

Angetriebenes Zahnradwaelzfräse-Werkzeug

Subject to change without notice.

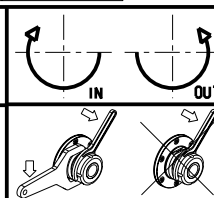

M.T. srl

Via Casino Albini 480  
 Tel. 0541/956034-957884  
 Fax 0541/956341

47842 S. GIOVANNI IN M. (RN)  
 e-mail: mtma@tmarchetti.com  
 http://www.tmmarchetti.com



MUR340-1-20