

ATTENZIONE - ATTENTION - ACHTUNG

- Con l'utensile orientato a 0° o 180°, non è possibile eseguire lavorazioni a centro-pezzo!
- It is not possible to make machining operations at the center of the part with tool oriented at 0° or at 180°
- Mit einem Werkzeug um 0° oder 180° orientiert, ist es nicht möglich, Verarbeitung von der Werkzeug-Mitte auszuführen.

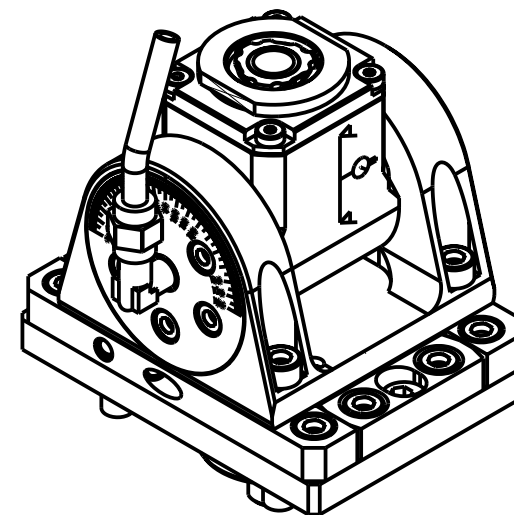

Cod. MT	Mandrino Spindle Spindel	I	RPM	Coppia Max Max Torque Max Drehmoment	Reversibile lato mandrino/contromandrino Reversible sub/main spindle side Umkehrbare Spindel-seite/ Gegenspindel-seite	Lubrificazione int. Coolant through Innenkuehlung	Lubrificazione est. Ext. coolant Aussenkuehlung	CHIAVI INCLUSE Keys included Schluessel inbegriffen			
					X	-	X	CHUB19_SP3	CHUB32	CHESL05	CHTAER16ZC
MYA0240116	ER A 16	1:1	6000	20Nm	X	-	X	CHUB19_SP3	CHUB32	CHESL05	CHTAER16ZC
MYA0240216	ER A 16	1:1	6000	20Nm	X	P=70bar	X	CHUB19_SP3	CHUB32	CHESL05	CHTAER16ZC

MIYANO

MOD: BNA 34-42 S/C/DHY/MSY/GTY - BNC-42C - ANX-42SYY

MODULO MOTORIZZATO ORIENTABILE ±90° H=48mm

±90° adjustable angle driven tool H=48mm

Angetriebenes Werkzeug schwenkbar ±90° H=48mm

Subject to change without notice.

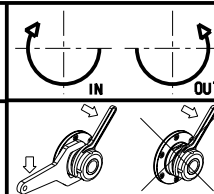

M.T. srl

Via Casino Albini 480
Tel. 0541/956034-957884
Fax 0541/956341

47842 S. GIOVANNI IN M. (RN)
e-mail: mtma@mtmarchetti.com
http://www.mtmarchetti.com



PAGINA MYA335-4-00