

ATTENZIONE - ATTENTION - ACHTUNG

- Per lo smontaggio degli utensili utilizzare sempre la chiave di contrasto come indicato nel manuale d'uso.
- For disassembly of the tools use always the contrast key as mentioned in the user instructions.
- Fuer das Abmontieren der Werkzeuge immer den Gegenschlüssel benutzen wie in der Bedienungsanleitung erwaeht.

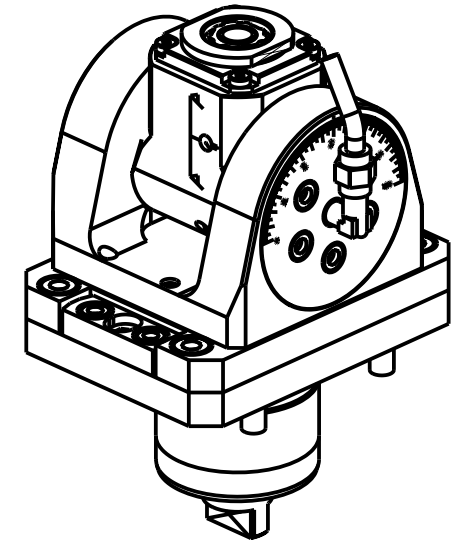

| Cod. MT | Mandrino Spindle Spindel | I | RPM | Coppia Max Max Torque Max Drehmoment | Reversibile lato mandrino/contromandrino Reversible sub/main spindle side Umkehrbare Spindel-seite/ Gegenspindel-seite | Lubrificazione int. Coolant through Innenkuehlung | Lubrificazione est. Ext. coolant Aussenkuehlung | CHIAVI INCLUSE Keys included Schluessel inbegriffen | | | |
|------------|--------------------------|-----|-------|--------------------------------------|--|---|---|---|---------|----------|-------------|
| | | | | | | | | C HUB19_SP3 | C HUB32 | C HESL06 | C HTAER16ZC |
| MYA0120316 | ERA16 | 1:2 | 12000 | 8Nm | X | - | X | C HUB19_SP3 | C HUB32 | C HESL06 | C HTAER16ZC |
| MYA0120416 | ERA16 | 1:2 | 12000 | 8Nm | X | P=70bar | X | C HUB19_SP3 | C HUB32 | C HESL06 | C HTAER16ZC |

MIYANO

MOD: ABX-51/64/80 SYY/THY

MODULO MOTORIZZATO ORIENTABILE +/-90° MOLTIPLICATO I=1:2 H=60mm

+/-90° adjustable angle driven tool geared-up I=1:2 H=60mm

Angetriebenes Werkzeug schwenkbar +/-90° uebersetzt I=1:2 H=60mm

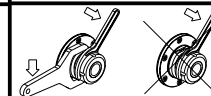

M.T. srl

Via Casino Albini 480
Tel. 0541/956034-957884
Fax 0541/956341
47842 S. GIOVANNI IN M. (RN)
e-mail: mtma@mtmarchetti.com
http://www.mtmarchetti.com



PAGINA MYA336-3-00

Subject to change without notice.

09/2023