

ATTENZIONE - ATTENTION - ACHTUNG

- Per lo smontaggio degli utensili utilizzare sempre la chiave di contrasto come indicato nel manuale d'uso.
- For disassembly of the tools use always the contrast key as mentioned in the user instructions.
- Fuer das Abmontieren der Werkzeuge immer den Gegenschluessel benutzen wie in der Bedienungsanleitung erwaeht.

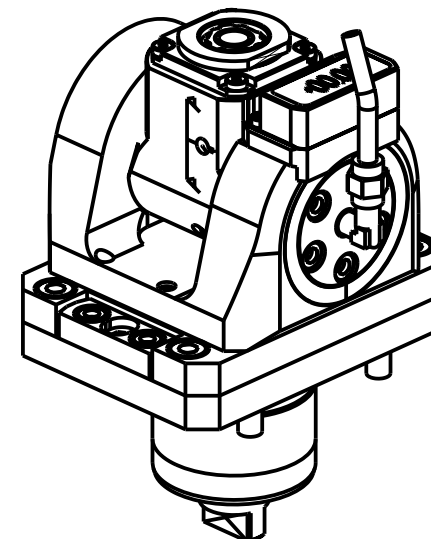

Cod. MT	Mandrino Spindle Spindel	I	RPM	Coppia Max Max Torque Max Drehmoment	Reversibile lato mandrino/contromandrino Reversible sub/main spindle side Umkehrbare Spindel-seite/ Gegenspindel-seite	Lubrificazione int. Coolant through Innenkuehlung	Lubrificazione est. Ext. coolant Aussenkuehlung	CHIAVI INCLUSE Keys included Schluessel inbegriffen			
								C HUB19_SP3	C HUB32	C HESL06	C HTAER16ZC
MYA0125316	ERA16	1:2	12000	8Nm	X	-	X	C HUB19_SP3	C HUB32	C HESL06	C HTAER16ZC
MYA0125416	ERA16	1:2	12000	8Nm	X	P=70bar	X	C HUB19_SP3	C HUB32	C HESL06	C HTAER16ZC

MIYANO

MOD: ABX-51/64/80 SYY/THY

MODULO MOTORIZZATO ORIENTABILE +/-90° MOLTIPLICATO I=1:2 CON NONIO DIGITALE H=60mm
 +/-90° adjustable angle driven tool geared-up I=1:2 with digital display H=60mm
 Angetriebenes Werkzeug schwenkbar +/-90° uebersetzt I=1:2 mit digital display H=60mm

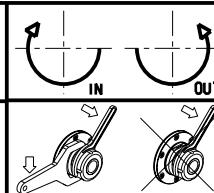

M.T. srl

Via Casino Albini 480
 Tel. 0541/956034-957884
 Fax 0541/956341
 47842 S. GIOVANNI IN M. (RN)
 e-mail: mtma@mtmarchetti.com
 http://www.mtmarchetti.com



PAGINA MYA336-3-01

Subject to change without notice.

09/2023